

# H160

Hype Performance Group



H160 (H160-B) Airbus Helicopter  
 Base Pack  
 Version 1.1 (Build .83) Last Updated: 2024/08  
 User Guide V 1.10

THIS SOFTWARE IS PROVIDED "AS IS" AND ANY EXPRESS OR IMPLIED WARRANTIES, INCLUDING, BUT NOT LIMITED TO, THE IMPLIED WARRANTIES OF MERCHANTABILITY AND FITNESS FOR A PARTICULAR PURPOSE ARE DISCLAIMED. IN NO EVENT SHALL THE COPYRIGHT HOLDER OR CONTRIBUTORS BE LIABLE FOR ANY DIRECT, INDIRECT, INCIDENTAL, SPECIAL, EXEMPLARY, OR CONSEQUENTIAL DAMAGES (INCLUDING, BUT NOT LIMITED TO, PROCUREMENT OF SUBSTITUTE GOODS OR SERVICES; LOSS OF USE, DATA, OR PROFITS; OR BUSINESS INTERRUPTION) HOWEVER CAUSED AND ON ANY THEORY OF LIABILITY, WHETHER IN CONTRACT, STRICT LIABILITY, OR TORT (INCLUDING NEGLIGENCE OR OTHERWISE) ARISING IN ANY WAY OUT OF THE USE OF THE SOFTWARE, EVEN IF ADVISED OF THE POSSIBILITY OF SUCH DAMAGE.

This simulation software is not supported or endorsed by Airbus SE or Airbus Helicopters. All trademarks and brand names are registered trademarks of the respective owners.  
 This product is compatible only with Microsoft Flight Simulator 2020

The H160 is a medium utility helicopter that was engineered with a focus on utilizing groundbreaking manufacturing methods, state-of-the-art production facilities and advanced materials to elevate the helicopter to a level of sophistication comparable to that of passenger jets and commercial airliners. Pilot workload in the H160 is reduced by the inclusion of advanced avionics and autopilot functionality. The HPG H160 shares many of the most appreciated features of the HPG H145 while providing more seating, higher max cruise speeds and longer range. The H160 offers new exciting features such as automatic takeoff modes for both vertical and forward takeoff assistance, as well as higher cruise speeds, longer range and much more passenger and crew capacity.

We use an installer/update program called **Hype Operations Center** to manage installation of our products. You will find easy installation, quick updates, downgrades and rollback to earlier versions as you prefer.

H160 has over 600 key bindings which are available for you to bind using Hype Operations Center. You can also directly send events and monitor local variables using programs like SPAD.next or FSUIPC.

This manual consists of:

- Included PDF-Documentation (see [\Community\hpg-airbus-h160\H160 Quick-Start.pdf](#))
- H145 User Guide (see [\Community\hpg-airbus-h145\H145 User Guide.pdf](#))
- CMA9000 FMS Supplement V 1.1
- [Hype Operation Center \(Internet\)](#)
- [Mission System \(Internet\)](#)

You can find other manuals and translations on <http://dvrgl.georgl.info>

With thanks to Dave and the development team for their excellent product, have fun  
 D-VRGL, FireHawk

# Content

Historical.....	8
Specifications.....	8
Dimensions.....	8
Characteristics.....	8
Performance.....	8
Getting Started.....	9
Installation.....	9
Flying Basics.....	9
Information for Livery Authors.....	9
Controls & Bindings.....	10
Primary Flight Controls.....	10
Beep Trim.....	10
Other Important Bindings.....	10
Custom Control Bindings.....	11
Trim Release.....	11
Example Control Profile.....	12
Settings for Xbox controller.....	12
Recommended MSFS Settings.....	13
Flight Simulator 2020.....	13
General Options – Camera.....	13
General Options – Data.....	13
General Options – Graphics.....	13
Assistance Options - Piloting.....	13
Flight Simulator 2024.....	14
General Options – Camera.....	14
General Options – Graphics.....	14
Assistances – Piloting.....	14
MSFS Cockpit Interaction System.....	15
Operating knobs with a center push function.....	15
H160 in Multiplayer.....	15
Aircraft Settings.....	16
H160 Tablet Setup.....	16
Cyclic Sensitivity.....	16
HANDS ON detection.....	16
Pedals Sensitivity.....	16
FEET ON detection.....	16
Cyclic Trim System.....	17
Pedals Trim System.....	17
Pedals ATT Mode.....	17
Gameplay Mode.....	17
Aircraft Damage.....	17
Vortex Ring State.....	17
Cyclic Follow-Up Trim.....	17
Cyclic Displace Center-Reset-Time.....	18
Collective Inc/Dec Step Size.....	18
View Documentation.....	18
Restore page to default.....	18
Cold & Dark.....	18
Ready for Takeoff.....	18
Checklists.....	19
General Limitations.....	19
Torque limitations.....	19
TOT limitations.....	20

N1 limitations.....	20
Procedures.....	21
Power-Up Procedures.....	21
Engine Start Procedure.....	22
AFCS Pre-Flight Test.....	23
Taxiing.....	23
Before Takeoff.....	23
Takeoff - Clear Area CAT A.....	23
Takeoff - Ground Helipad CAT A.....	23
Climb.....	24
Level Flight.....	24
Descent.....	24
Before Landing.....	24
Landing - Standard (Level surface).....	25
Landing – Sloped.....	25
Shutdown.....	25
Systems.....	26
Cockpit Arrangement.....	26
MFDs.....	27
FND Page.....	28
First Limit Indicator (FLI).....	28
All Engines Operative (AEO).....	28
One-Engine-Inoperative (OEI).....	29
Airspeed indicator.....	29
Stopwatch (chronometer).....	29
Set altimeter (BARO).....	29
HSI View.....	29
SCT (Sector) View.....	30
HOV (Hover) View.....	30
SVS (Synthetic vision).....	30
Wind indicator.....	30
NAVD Page.....	31
NAVD Page (DATA subformat).....	31
NAVD Page (Sector view).....	31
VMS Page.....	32
VMS Page - Engine indications.....	32
VMS Main Page (MAIN subformat).....	33
VMS Main Page (STATUS subformat).....	34
VMS Main Page (REPORT subformat).....	34
VMS Main Page (EPC subformat).....	34
VMS Main Page (CONF subformat).....	34
VMS Main Page (WEIGHT subformat).....	34
VMS Page Flight Control.....	35
VMS Page Electric.....	35
VMS Page Fuel.....	35
VMS Page Hydraulic.....	35
VMS Page RCNF (Reconfigure format).....	36
VMS Page System (System format).....	36
VMS Page XMSN.....	36
DMAP Page.....	37
Data Sources (Advanced).....	37
MISC Page.....	37
Emergency Floats.....	38
Windshield Wiper.....	38
Terrain Awareness and Warning System (HTAWS).....	38
Wheel.....	38

Standby instrument (IESI).....	38
Cellphone.....	39
Cabin air control panel (GPCP).....	39
Autopilot Control Panel.....	39
Upper Modes.....	39
Collective Modes.....	39
Roll/Yaw Modes.....	40
Modes not on the APCP.....	40
Beep Trim.....	40
Cyclic grip.....	40
Collective grip.....	40
NPX138 FM Transceiver.....	40
Weather Radar.....	41
Aircraft Lights.....	41
Cockpit lights.....	41
Instrument Panel lights.....	42
Exterior lights.....	42
Emergency Locator Transmitter (ELT).....	42
Maintenance panel.....	42
Overhead Panel Copilot.....	42
Overhead Panel Pilot.....	43
External Power.....	43
Engine Filters (IBF).....	43
Failures & Damage Model.....	43
Failure & Maintenance app.....	44
Aircraft Failure Variables.....	45
Flight Management System.....	46
GTN750 Flight Management System.....	46
GTN750 Software Options.....	46
Pms50 GTN750.....	46
Checklists.....	46
Registration.....	46
Disable an individual FMS unit.....	46
Operating the GTN750.....	47
Direct-To airport procedure.....	47
Direct-To: Select a nearby airport.....	47
Direct-To: Select an airport by name.....	47
Enter transponder code and turn ON and OFF.....	48
CMA9000 FMS Supplement.....	50
System Overview.....	50
Display Function Buttons.....	50
Keypad Function Buttons.....	50
Execute Function.....	51
Flight Plan Functions.....	51
Entering origin and destination airports.....	51
Add En-route legs.....	51
Selecting Departure procedures.....	52
Selecting Arrival and Approach procedures.....	52
Deleting the flight plan.....	52
Direct-To.....	52
RTE 2 Option.....	53
Aircraft Functions.....	53
Find nearby airports and Nav aids.....	53
Tune COM1 or COM2 radio.....	53
Tune NAV1 or NAV2 radio.....	53
Enter transponder code.....	53

Turn transponder ON and OFF.....	54
Advanced Functions.....	54
Mark on top (create waypoint).....	54
Enter PlaceBearing/Distance waypoint.....	54
Enter or modify a holding pattern.....	54
Enter or modify a search pattern (SAR).....	54
Editing the Company Database.....	55
Editing the User Database.....	55
Select flight plan from company route list.....	55
Hype Tablet.....	56
Apps.....	56
Aircraft (Setup).....	56
Setup.....	56
Equipment.....	57
Options.....	57
Crew & Payload.....	58
Maps app.....	58
Advanced Configuration (Optional).....	58
Documents app.....	58
Neopad app.....	59
Web Browser.....	59
EFB Connect (Web Browser).....	59
LittleNavMap app.....	59
Advanced Configuration.....	59
Events Tester.....	60
Sound Mixer.....	60
Direction Finder.....	60
Hype Radio.....	60
Wallpaper.....	60
Action center.....	60
Always-visible sections.....	60
Contextual sections.....	61
Status bar.....	62
GPU status icons.....	62
Cargo Hook (with Remote Hook) status icons.....	62
Bambi bucket status icons.....	62
Other status icons.....	63
AFCS (Autoflight System).....	64
Background.....	64
Trim Release.....	64
Follow-Up Trim.....	64
AFCS OFF and A.TRIM OFF Operation.....	64
ATT / Attitude Hold.....	64
DSAS / Digital SAS.....	64
HDG and TRK / Heading Hold.....	64
VS and FPA / Vertical Speed.....	65
ALT / Altitude Hold.....	65
ALT.A / Altitude Acquire.....	65
IAS / Indicated Airspeed Hold.....	65
GA / Go-Around.....	65
GTC / Ground Trajectory Command.....	65
GTC.H / Auto Hover.....	65
VOR / VOR Navigation.....	65
LOC / Localizer.....	66
NAV / FMS Navigation.....	66
GS / Localizer Glideslope.....	66

APP / Approach.....66

V.APP / Vertical Approach.....66

Livery Author Info.....66

    Paint Kit.....66

    Selecting Variant.....66

    Controlling External Parts.....67

    Sample Configuration.....67

    Configuring external crew.....67

    Custom external crew.....67

    Setting Tablet Wallpaper.....67

    Adding documents to the Documents app.....68

Download and Install H160.....68

    Download & Install.....68

    Copy & Install.....70

    How to Install test version.....70

    Installation with the download file from Discord.....70

    HOW to Install HTAWS Database.....70

    How to Install Action Pack.....70

    After Installation.....70

        Download Cache.....70

        Use of Addon Linker.....70

        Activation trouble.....70

    Troubleshooting.....71

        Microsoft Teams or other app won't install.....71

    Known Issues.....71

How are helicopter buttons configured?.....72

    Normal assignment.....72

    Assignment with HOC.....72

    How do I assign a stream deck?.....73

Tips and tricks.....74

    How do I find the community folder?.....74

        In Developer Mode.....74

        In the settings.....75

    GTC and how it works.....75

    HANDS ON detection setting.....75

    Trim release.....76

    Difference between 'trim release' and 'spring override'.....76

    Correct setting of Trim Release.....76

        spring joystick:.....76

        no-spring or helicopter cyclic:.....76

        Force Feedback cyclic:.....77

    How to make an approach:.....77

    I have installed 2024 or switched to it and cannot find the standard HPG livery (anymore).....77

    How can I integrate night vision?.....78

    What can I do if OSM stops providing map data for the DMAP?.....78

SDK H:Events.....79

    Home Cockpit SDK.....79

    Overhead Panel.....79

    Overhead Panel.....79

    Engine Control Panel (ECP).....80

    Autopilot Control Panel (APCP).....81

    Cyclic Control.....81

    Collective Control.....82

    Misc.....82

    Cabin.....82

    Misc.....83

Center Console WXRCP.....84  
 Tablet.....84  
 Hype Radio App.....85  
 Tablet.....85  
 Equipment Setup.....86  
 MFDs.....86  
 IESI.....88  
 Center Console Other.....88  
 Sensor Pod.....89  
 GTN750\_1 Bezel.....89  
 GTN750\_2 Bezel.....89  
 CMA9000 FMS\_1.....89  
 CMA9000 FMS\_2.....91  
 CARLS Tactical Radio.....92  
 Enviromental Control (ECS).....92  
 Troubleshooting.....94  
   I can't find my license key.....94  
   MFD screens are black or the tablet won't open.....94  
   GTN750 screens are black.....94  
   It feels like I am fighting the aircraft when I fly.....94  
   The aircraft is not reliable when flying with autopilot upper modes (HDG, IAS, ALT).....94  
   Click-spots in the virtual cockpit are offset.....94  
   The camera moves in an erratic way, mostly when taking off and landing.....94  
   I have bound a hotkey but it always sends multiple commands.....94  
   Aircraft has pink textures.....94  
   MGB Over limit / Aircraft won't takeoff.....95  
   Unable to start at MSFS Helipads.....95  
   Problems with WU/SU update.....95  
 Known Issues.....96  
   WTT Mode is inoperative with helicopters in MSFS.....96  
   FSRealistic Low-altitude turbulence is not compatible with helicopters.....96  
   Tablet Time option is off by 1 hour.....96  
   Helicopters don't spawn correctly on some helipads.....96  
   Helicopter ground effect transition is abrupt when approaching elevated helipads.....96  
   FS 2024: No fuel when start on runway or helipad.....96  
   FS 2024: \*\*Pause\*\* (ESC) break collective.....96  
   FS 2024: Starting cold&dark and stand in front of the helicopter.....96  
   FS 2024: TDS GTNXi is currently blocked.....96  
 Acronym List.....97  
 MSFS/H160 Default-Function.....99  
 Changelog H160.....102  
   .83.....102  
   .82.....102  
   .78.....102  
   .77.....102  
 Changelog User Guide.....103

## Historical

The H160 was unveiled at the Heli-Expo in Orlando in March 2015. The first production aircraft made its maiden flight in 2018. EASA type certification was granted in mid-2020 and FAA certification in 2023.

With two shaft turbines, the bent rotor blades and the 12° inclined fenestron with the tailplane at the rear, the helicopter is easily recognizable. All of this is designed to reduce performance when hovering. The helicopter is the first civilian helicopter to be made entirely from composite materials. In tests in 2016, an H160 reached 337 km/h.

Developed as a multi-purpose helicopter, the first flight was in June 2015. The first major order announcement came from the French armed forces in 2017. Delivery of the 169 units ordered is planned from 2027. The largest single order to date came in 2023 from the Chinese GDAT, which ordered 50 units. Planned areas of use include air rescue, transport and, in the military version, ship defense, reconnaissance, airspace protection and air rescue.

## Specifications

### Dimensions

D-Value	15.67 m
Rotor diameter	13.40 m
Internal cabin volume	up to 7.3 m <sup>3</sup>

### Characteristics

Crew and passengers	1 or 2 pilots plus 19 passengers
Max takeoff weight	6,050 kg
Useful load	up to 2,000 kg
Engine	2 * Safran Helicopter Arrano 1A
Standard fuel tank capacity	1,120 kg
Takeoff power	955 kW

### Performance

Recommended cruise speed	255 km/h
Max. range with standard fuel tanks	890 km
Max. endurance with standard fuel tanks	4h 30min
Flight envelope (temperature)	-20°C to +37°C limited to 50°C
Max flight altitude	6,096 m

# Getting Started

## Installation

Complete all three steps:

1. [Download & Install H160](#)
2. Configure [Controls & Bindings](#)
3. Learn about [Aircraft Settings](#)

If you have already installed the H160, copy the directories from 2020 directly into the community directory of 2024.

- hpg-airbus-h160
- hpg-airbus-h160-usersetup
- hpg-hatws-data

Change your community folder in HYPE Operation Center from 2020 to 2024.

PMS50-gtn750 get the updated MFS24 version directly from pms50's website!

## Flying Basics

H160 is similar to something like a mix of an airliner and a traditional helicopter.

Before flight, the pilot should turn on [A.TRIM](#) , [AP1](#) , [AP2](#) and [BKUP](#) (These are all on the Autopilot control panel or APCP, which is on the center console above the Flight Management Systems).

The pilot shall hold [Cyclic Trim Release](#) before raising the collective for takeoff. The pilot will lift off from the ground and only once in a hover may the trim be released. Once the trim is released, the aircraft AFCS will continually attempt to maintain the current attitude where the pilot last let go of trim release.

The autopilot has more than just attitude stabilization (which is the normal mode, and not visualized on the MFD), there are also so-called [UPPER MODES](#) . These upper modes are traditional flight control modes like HDG (heading hold), ALT (altitude hold), but also ground-based GPS modes likes GTC. You can use the tablet autopilot panel (click the clock at the top of the tablet) to learn more about the modes and to issue commands without setting up buttons on your controller.

Remember, you need to heed the limits on the FLI (the vertical tape to the left side of your pilot MFD). Take-off power (yellow) is allowed for 30 minutes per flight. Once you exceed and go "into the red", the engines won't be able to keep up and your rotor rpm will slow. If the rotor rpm slows below 80%, you will fall out of the sky.

Next you can learn more about the [AFCS](#) and other [Aircraft Systems](#) and [Procedures \(Checklists\)](#). IF you don't know about used Acronym's, go to the [Acronym List](#).

## Information for Livery Authors

- Paint Kit
- Configure external hardware JSON
- texture.cfg for each variant

See [Livery Author Info](#)

## Controls & Bindings

Control bindings are now available in either the previous fixed-wing bindings or the new (SU11 and later) native helicopter bindings. You can use either version, but do not use both at once for the same axis as this will result in loss of control.

### Primary Flight Controls

Function	MSFS Axis Bindings	Notes
Collective	THROTTLE AXIS or COLLECTIVE AXIS	Pick only one axis. The H160 has a FADEC (full authority digital engine control) which controls the engine fuel metering without a manual throttle axis, even in reversion mode.
Cyclic Pitch	ELEVATOR AXIS or CYCLIC LONGITUDINAL AXIS	
Cyclic Roll	AILERONS AXIS or CYCLIC LATERAL AXIS	
Yaw Pedals	RUDDER AXIS or TAIL ROTOR AXIS *	You may also use the split-rudder axis ( RUDDER AXIS LEFT and RUDDER AXIS RIGHT )

Button inputs are also available on all axis.

### Beep Trim

Function	MSFS Axis Bindings
Cyclic Pitch	INCREASE ROTOR LONGITUDINAL TRIM and DECREASE ROTOR LONGITUDINAL TRIM
Cyclic Roll	INCREASE ROTOR LATERAL TRIM and DECREASE ROTOR LATERAL TRIM
Collective	INCREASE AUTOPILOT N1 REFERENCE and DECREASE AUTOPILOT N1 REFERENCE
Yaw Pedals *	RUDDER TRIM LEFT and RUDDER TRIM RIGHT

\* - Yaw trim is known as Collective Left/Right beep trim.

### Other Important Bindings

Function	MSFS Binding	Notes
Cyclic Trim Release	ROTOR TRIM RESET	Pause the AFCS logic to take manual control, as well as communicating your intents to the AFCS. Hold this button down while manipulating the cyclic.
AP/BKUP ON	AUTOPILOT ON	Press once to engage BKUP/AP1/AP2, press again to engage ALT/HDG/IAS.
AP/UM OFF	AUTOPILOT OFF	Press once to cancel upper modes. Hold for 2 seconds to clear all bugs
AP/BKUP CUT	TOGGLE DISENGAGE AUTOPILOT	Press once to disengage AP1/AP2. Press again to disengage BKUP.
AP/GTC	TOGGLE AUTO HOVER	Press once for GTC. Press twice for GTC.H
RESET (message list)	ANNUNCIATOR SWITCH OFF	Clear message list on FND page
OEI HI/LO	ARM AUTO THROTTLE	Toggle between OEI HIGH and OEI LOW rating
Go Around	AUTO THROTTLE TO GA	Activate Go-Around mode
Bambi Bucket Dump Cargo Attach/Detach Fire Weapons	TOGGLE YAW DAMPER	

Take care to use the **On Release** logic in MSFS bindings, to avoid key repeating. This does not apply to Trim Release as it is configured to be held with repeating.

## Custom Control Bindings

Add custom control bindings through Hype Operations Center.

1. Open [Hype Operations Center](#) (You must have version 1.0.31 or higher for language selection)
2. Select your language under [Settings](#) (this ensures you see localized text which will be the same as you see later in MSFS)
3. Visit the H160 page, then click [View/Modify Key Bindings](#)
4. Scroll to the bottom and click [Add Binding](#) to define a new control binding
5. Pick a MSFS event (nearly at random) on the left side. You can start with [SET ADF VOLUME](#)
6. Pick the H160 function on the right side (You may test this in the cockpit using the Event Tester tablet app)
7. Click Save.
8. If MSFS is already running, you must now **restart the flight** (not the full simulator).
9. In MSFS, select the binding you picked in step 5, and the button on your controller.

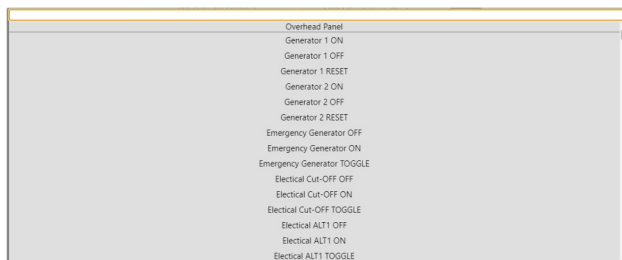

You're done. Pressing the button should now activate the H160 function. You can repeat this process to create as many custom bindings as needed.

- \* - MSFS [HELD](#) events are likely to have incorrect/odd behavior with repeating.
- \* - Using the 'On Release' logic in MSFS often avoids incorrect key repeating which could break the ability to use a toggle-style button.

Note: The top line above MSFS event and H160 function is a searchline where you can enter some text.

## Trim Release

Trim Release (Cyclic Trim Release) is a button on the cyclic control which the pilot holds anytime they are manipulating the cyclic. This is a very important aspect of H160 and doing so both pauses the AFCS (so it doesn't fight you) and also gives you maximum precision (no deadzone).

There are multiple bindings you can choose from, the HOLD version (which you hold continually) or the LATCH version (which you simply click), which you may assign to a switch or other logic. When pressing Trim Release or hands on detection is active, you will see "OVERRIDE" at FND-page.



If you fail to use trim release, you will fight the autoflight systems!

Binding	Notes
<a href="#">Cyclic Control - Trim Release (HOLD)</a>	Recommended. This button will keep the trim release open until released, allowing for precise manual flight
<a href="#">Cyclic Control - Trim Release (Latch: Open)</a>	This will set trim release to the open (pushed by pilot) state
<a href="#">Cyclic Control - Trim Release (Latch: Closed)</a>	This will restore trim release to the closed (not pushed) state
<a href="#">Cyclic Control - Trim Release (Latch: Toggle)</a>	Clicking this button will toggle the trim release state

There is also a lesser-used [Collective Trim Release](#). This command is only needed when the AFCS has a collective mode engaged (like ALT, VS, CR.HT, V.APP etc.). Often it is easier to simply issue [AP/UM OFF](#) and cancel the mode instead.

Binding	Notes
<a href="#">Collective Control - Trim Release (HOLD)</a>	Recommended. This button will keep the trim release open until released, enabling override of modes engaged on the collective axis
<a href="#">Collective Control - Trim Release (Latch: Open)</a>	This will set trim release to the open (pushed by pilot) state
<a href="#">Collective Control - Trim Release (Latch: Closed)</a>	This will restore trim release to the closed (not pushed) state
<a href="#">Collective Control - Trim Release (Latch: Toggle)</a>	Clicking this button will toggle the trim release state

## Example Control Profile



	H145 Function	Notes
1	AP/GTC	Press once: Engage GTC mode (ground-speed hold), Press twice: Engage GTC.H mode (auto hover)
2	UP: AP/BKUP ON, DOWN: AP/UM OFF	Engage Autopilot, Disengage Upper Modes
3	AP/BKUP CUT	Press once: Disengage AP1 and AP2 system Press twice: Disengage Backup SAS
4	CYCLIC TRIM RELEASE	Press and hold whenever making manual aircraft inputs.
5	RESET	Acknowledge any new messages in the Message List.
6	CYCLIC BEEP TRIM (UP, LEFT, DOWN, RIGHT)	4-way cyclic beep trim. Issue inputs in the respective axis (up and down is pitch, left and right is roll) in AFCS modes and manual trim with the AFCS off.
7	COLLECTIVE BEEP TRIM (LEFT, RIGHT)	4-way collective beep trim. Issue inputs in the respective axis (up and down is collective, left and right is yaw)
8	COLLECTIVE BEEP TRIM	(UP) See above.
9	COLLECTIVE BEEP TRIM	(DOWN) See Above.

## Settings for Xbox controller

The default Xbox controller profile will work with H160.

These settings will better accommodate the small throw of the Xbox controller joystick:

H160 Tablet:

- **Cyclic Control** : Centering-Springs
- **Follow-Up Trim** : Both
- **Pedal trim system**: Software (default)
- **FEED On detection strategy**: Deadzone (default)

MSFS Piloting Assistance:

- **Tail Rotor** : ON
- **Cyclic** : OFF

## Recommended MSFS Settings

### Flight Simulator 2020

#### General Options – Camera

CAMERA SHAKE: OFF

Camera Shake causes some problems with the helicopter flight models.



#### General Options – Data

ONLINE FUNCTIONALITY: ON

Online functionality is required for H160 to activate, as well as for a number of H160 features like online maps and weather.



#### General Options – Graphics

Glass Cockpit Refresh Rate: High



#### Assistance Options - Piloting

AUTO-RUDDER: OFF

ASSISTED YOKE: OFF

ASSISTED LANDING: OFF

ASSISTED TAKEOFF: OFF

AI ANTI-STALL PROTECTION: OFF

AI AUTO-TRIM: OFF

ASSISTED CONTROLLER SENSITIVITY: OFF



Fixed-wing pilot assistance settings cause control problems for helicopter flight models. Unexpected behaviors are very often caused by these settings and it is very important that they are disabled.

## Flight Simulator 2024

### General Options – Camera

CAMERA SHAKE: OFF

Camera Shake causes some problems with the helicopter flight models.



### General Options – Graphics

Glass Cockpit Refresh Rate: High

If you fly VR, don't forget to set this in VR as well.

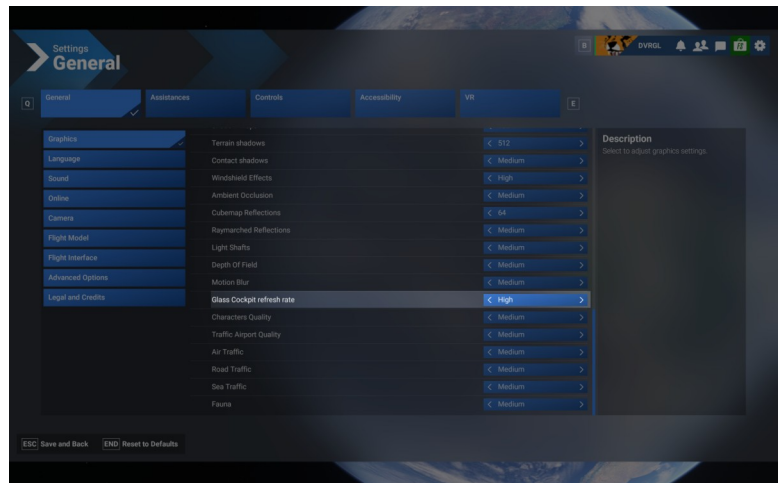

### Assistances – Piloting

Auto-Rudder:	OFF
Assisted Yoke:	OFF
AI Auto-Trim:	OFF
Helicopters Assisted Cyclic	OFF
Helicopters Assisted Tail Rotor	OFF
Helicopters Assisted Collective	OFF
Assisted Controller Sensitivity	OFF
Automixture	OFF
Gyro Drift	OFF
Gyro Drift	OFF
Gyro Drift (realistic)	ON

(Reason being, these are across the board settings and any physical (spinning gyro) will, in fact, drift a bit and must be accounted for by the pilot.)

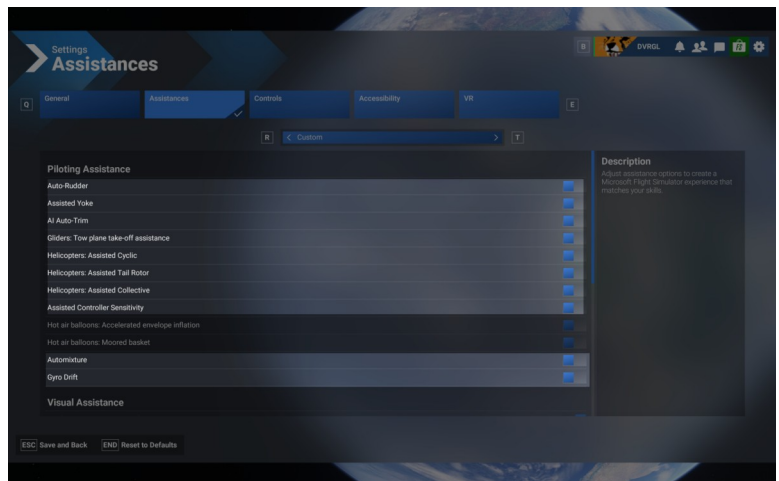

## MSFS Cockpit Interaction System

Microsoft Flight Simulator has two modes of operating interactive elements within the virtual cockpit. These modes are controlled by the Cockpit Interaction System setting, under the Accessibility category of General Options. You may be using either setting depending on when you first installed the game.

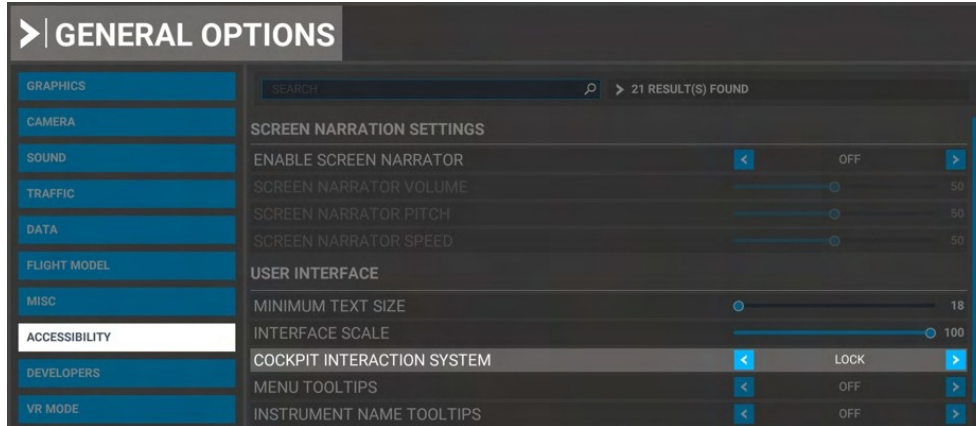

**Lock:** Xbox-preferred interaction method, new in Sim Update 5. This is the default setting for new players. This mode uses a blue and yellow visual highlight on most (but not all) interactive elements.

**Legacy:** Classic input method used by FSX and Prepar3D. Moving the mouse over an interactive element will show a cursor but will not change their visual appearance of that element.

### Operating knobs with a center push function

Lock:

1. Target a knob and press-and-hold Left mouse button
2. Click the Right mouse button
3. Release the Left mouse button

Legacy:

1. Target the center of the knob (not the left/right or top/bottom sides)
2. Click the Left mouse button



## H160 in Multiplayer

### Seeing other helicopters

In order to see another H160 in MSFS multiplayer you will need to ensure that both players:

1. Have the same aircraft installed
2. Have the same livery installed
3. Configured the MSFS setting Use Generic Plane Models to OFF

If these three conditions are not met, you will see a hovering fixed-wing plane in place of a player who is actually flying a helicopter

### Limitations

Without helicopter support in MSFS the H160 has many custom systems and implementations which are not normal for other aircraft.

The lack of door and helicopter variables means that you will see other players showing the same as your aircraft configuration. This includes doors, the rotor spinning state, WSPS, radome and other external part configurations. Later we may be able to remove these restrictions.



## Aircraft Settings

Aircraft settings are generally controlled on the H160 tablet, inside the Aircraft app.

### H160 Tablet Setup

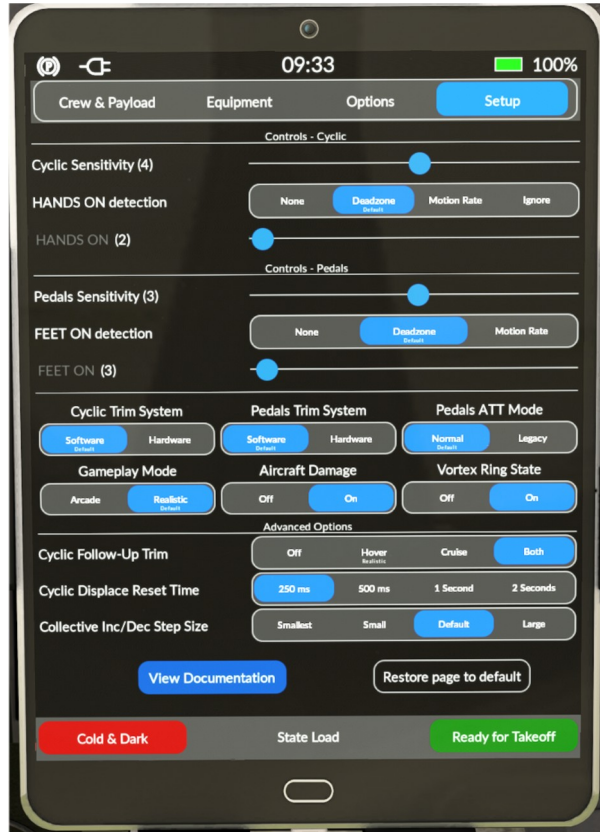

#### Cyclic Sensitivity

This setting is essentially the same as the MSFS Controls Sensitivity setting. -100 is full stability and +100 is no stability. In other words, full left is easiest, and moving to the right makes it more sensitive.

#### HANDS ON detection

This setting controls the HANDS ON detection strategy. The slider below corresponds to the threshold relative to the selected strategy.

Strategy	Description
None	Used for Force-Feedback controllers. In this mode there is no HANDS ON detection unless <code>L:FFB_HANDS_ON_CYCLIC=1</code> .
Motion Rate	Used for any controller. Detection is based on rate of motion. The slider will adjust the relative motion rate which triggers detection.
Deadzone	Used for any controller. Detection is based on the deflection of the stick exceeding a specific threshold, which is set by the slider below.
Ignore	Used for controllers without sufficient ability to hold a position. In this mode the cyclic is completely ignored when using AFCS upper modes. Recommended for sticks without feathers.

#### Pedals Sensitivity

This setting is essentially the same as the MSFS Controls Sensitivity setting.

#### FEET ON detection

This setting controls the FEET ON detection strategy. The slider below corresponds to the threshold relative to the selected strategy.

Strategy	Description
None	Used for Force-Feedback controllers. In this mode there is no FEET ON detection unless <code>L:FFB_FEET_ON_PEDALS=1</code> .
Motion Rate	Used for any controller. Detection is based on rate of motion. The slider will adjust the relative motion rate which triggers detection.
Deadzone	Used for any controller. Detection is based on the deflection of the stick exceeding a specific

	threshold, which is set by the slider below.
--	--

### Cyclic Trim System

This setting controls whether there is a virtual trim (good for controllers with springs) or a hardware trim (good for Force-feedback controllers).

Strategy	Description
Software	The virtual trim point is visible on the VMS CTRL page as a blue cursor. It will move slowly to follow the stick and relax any forces.
Hardware	The virtual trim is disabled, Force-Feedback controllers are likely in use.

### Pedals Trim System

This setting controls whether there is a virtual trim (good for controllers with springs) or a hardware trim (good for Force-feedback controllers).

Strategy	Description
Software	The virtual trim point is visible on the VMS CTRL page as a blue cursor. It will move slowly to follow the pedals and relax any forces.
Hardware	The virtual trim is disabled, Force-Feedback controllers are likely in use.

### Pedals ATT Mode

This setting is provided for compatibility with previous usage.

Strategy	Description
Normal	ATT mode will stabilize and hold heading in hover.
Legacy	ATT mode will not stabilize and hold heading in hover.

### Gameplay Mode

This setting provides an easier flight model for users with less comprehensive hardware.

Strategy	Description
Realistic	Realistic SAS implementation.
Arcade	Heavy-handed SAS implementation.

### Aircraft Damage

This setting configures the wear and damage model for the aircraft.

Strategy	Description
Off	No damage. Check that your MSFS damage is also turned off.
On	Engine damage, IBF clogging.

### Vortex Ring State

This setting configures the VRS model on top of the MSFS flight dynamics. VRS is a dangerous condition where lift is lost.

Strategy	Description
Off	VRS model is not active.
On	VRS is active, avoid descent below 500fpm when below 20kias.

### Cyclic Follow-Up Trim

This setting configures the Follow-Up Trim behavior.

Strategy	Description
Off	Trim Release must be used to update AFCS attitude setpoints.
Hover	Hands On detection in hover domain will result in updating AFCS attitude setpoints.
Cruise	Hands On detection in cruise domain will result in updating AFCS attitude setpoints.
Both	Hands On detection in both hover and cruise domain will result in updating AFCS attitude setpoints.

### **Cyclic Displace Center-Reset-Time**

This setting configures how long the cyclic is disabled after the Displace-Center binding function is used.

### **Collective Inc/Dec Step Size**

This setting configures how much collective is added or remove when clicking increment/decrement buttons. This does not apply when using an axis binding.

### **View Documentation**

Opens a Web-Browser and load the online [H160-Guide](#). Be carefull if in VR.

### **Restore page to default**

Resets the settings to default values.

### **Cold & Dark**

This switch puts the airplane in a switched-off state. It is used, for example, when taking off from a heliport or runway as all systems are always automatically started up here.

### **Ready for Takeoff**

This switch makes the aircraft ready for take-off when the button is pressed.

# Checklists

## General Limitations

The H160 shall be operated in compliance with the limitations in this section. This helicopter is approved for flight under VFR and IFR flight rules in addition to overwater operation.

The following are prohibited:

- Aerobatic maneuvers
- Flight into icing conditions. Should icing conditions be encountered unexpectedly, the conditions shall be left immediately

Limitation	
Maximum speed for starting and stopping the rotor	50kt
Maximum relative wind speed from any direction (except headwind)	25kt (45kt with headwind (+/- 30°))
Sloped landing limitation	Sloping nose down: 8° Sloping up to the right: 8° Sloping up to the left: 8° Sloping nose up: 12°
Maximum operating altitude	20,000FT PA
Maximum operating altitude for takeoff, hover and landing	20,000FT PA or DA (whichever is less)
Maximum air temperature Minimum air temperature <b>Or with cold weather kit:</b> Maximum air temperature Minimum air temperature	+37°C (max +50°C) -20°C to ISA  +50C -40C
Ground operations duration when > 40C OAT	Ground operations limited to 20 minutes  <b>NOTE:</b> When >35C OAT, lower cockpit temp by using max ventilation
Maximum mass in flight Useful load	6050kg 2000kg
V <sub>[NE]</sub>	170 KIAS or less (see Airspeed indicator)

## Torque limitations

	AEO Limitation	Torque
1	Max continuous power (no limit)	2x93.6%
2	Take-off power (30mins)	2x100% below Vy+10 KIAS 2x97.7% above Vy+30 kts
3	Transient limit (20 sec unintended use)	2x108%



Above Vy+5kt, take-off power will gradually disappear. The limits on the engine indications and the FLI will move according to the chart:

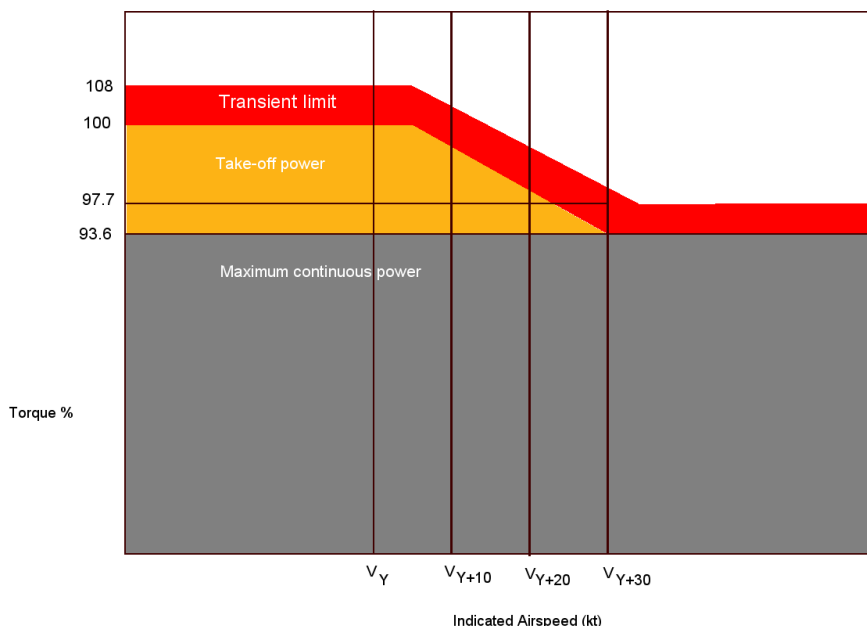

	OEI Limitation	Torque
1	Max continuous power (no limit)	1x112.1%
2	2-minute power	1x127.5%
3	30-second power	1x145%



**TOT limitations**

	Starting Limitation	TOT
1	Continuous starting	800C
2	Transient starting (max 10 seconds)	850C

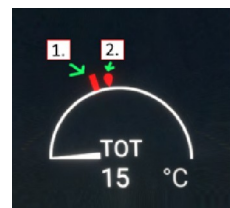

	AEO Limitation	TOT
1	Max continuous	886C
2	Take-off power (max 30 minutes)	912C
3	Transient limit (unintended use)	934C

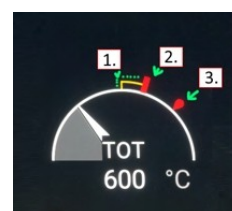

	OEI Limitation	TOT
1	Max continuous	914C
2	2-minute power	957C
3	30-second power	991C



**N1 limitations**

There's 3 Ns everybody should know about:

N1 (one per engine): Engine compressor speed. This is the part of the engine making power. The N1 will vary from around 60% to just over 100%. N1 is controlled by the FADEC, and it looks at the NR (rotor rpm) and then provides fuel to the engine until the NR is where it should be.

N2 (one per engine): This is how fast the power shaft on the engine is spinning. this shaft is what provides power to the rotor. N2 shafts spin up to 100% and then stay there (when at flight - they're 80% for idle). The reason N2 is important is

A) if the N2 falls, the engine isn't making power and

B) if the N2 exceeds some value, like 120%, then the engine will be shut down and the rotor will be disconnected.

This overspeed case is rare, and in real life there is also a lockout so once one engine overspeeds and is shut off the second engine will not be subject to shutdown, in case it is a sensor error or some such.

NR (just one rotor): How fast the [R]otor is spinning. About 100% is nominal but the "target datum" is usually not actually 100%, it can be anywhere from about 97 to 105.

The red and yellow indications inside/outside are showing the expected safe operating parameter.

	AEO Limitation	N1
1	Max continuous	103%
2	Take-off power (max 30 minutes)	104%
3	Transient limit (unintended use)	105.5%

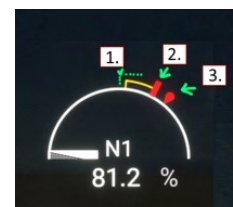

	OEI Limitation	N1
1	Max continuous	104.5%
2	2-minute power	105.6%
3	30-second power	107.8%

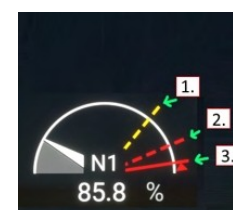







## Procedures

Procedures below are realistic, adapted from the H160-B flight manual and simplified where necessary. A typical flight may make use of the included procedures as follows:

Procedure	Purpose	Notes
Cockpit safety inspection	Confirm cockpit switches are in a safe position before bringing power to the aircraft.	Not included, Cold & Dark startup at a gate has already completed these steps for you.
Power-Up	Bring power to the aircraft after storage or otherwise being off	After Power-Up the pilots have several options: 1. Start engines 2. Engage RLG (Radio Listening on Ground) to activate the position lights, radios and navigation equipment 3. Connect a GPU (Ground Power Unit) to the aircraft to avoid draining the batteries Eventually, the pilots must either proceed to start engines, or conduct the Shutdown checklist.
1. Starting Engine 1 2. Starting Engine 2 3. After Engine Start 4. AFCS Pre-Flight Test	These 4 checklists should be conducted together in sequence	If there is a problem starting engines, the start should be aborted and the <b>Shutdown</b> checklist executed.
1. Taxiing 2. Before Takeoff	Taxiing checklist needs to be executed before leaving the parking position, and is used even if ground taxi or air taxi will not be conducted (e.g. if departing from the parking position directly).	
1. Takeoff - Clear Area (CAT A)  -OR- 2. Takeoff – Ground Helipad (CAT A)		Clear Area takeoff may be used when there are no obstructions in front of you (such as a runway). Should an engine fail before the TDP (takeoff decision point), then you can land on the runway.  A vertical takeoff (suitable for restricted area, like an offsite landing) or rearward takeoff can be used and should an engine fail before the TDP, the pilot may return to the start position.
Climb Level Flight Descent Before Landing		
Landing - Standard -OR- Landing - Sloped		
Shutdown		Remove power from the aircraft.

### Power-Up Procedures

This is the first checklist. This checklist brings power onto the aircraft and is used prior to starting engines.

<p><b>Overhead Panel</b></p> <p>1. BAT 1, BAT 2 ..... ON                  2. GEN 1, GEN2, EGEN ..... ON                  3. DC GPU (If Connected) ..... ON                  4. PWR-UP TEST OK ..... CHECK                  5. RA1, RA2 ..... ON                  6. FMS1, FMS2 ..... ON                  7. LAMP TEST ..... TEST                      a. "AUDIO TEST" voice message ..... AUDIBLE                      b. Lights illuminated ..... CHECK</p>	<p>NOTE: MFD3 (copilot inboard) will not have any power until either the GPU is connected or a generator is online.</p> <p style="text-align: center;"><b>GPU Status</b></p> <table border="1" style="width: 100%; text-align: center;"> <tr> <td style="width: 50%;"> Available</td> <td style="width: 50%;"> Connected</td> </tr> </table>	 Available	 Connected
 Available	 Connected		
<p><b>Pilot MFD (FND page)</b></p> <p>7. Message List ..... CHECK and ACKNOWLEDGE                  8. FND page ..... CHECK parameters validity                  9. Heading ..... COMPARE with Standby Compass                  10. Altimeters and IESI ..... SET                  11. Decision Height and Decision Altitude..... AS REQUIRED                  12. Fuel Quantity ..... CHECK</p>	<p>There are 3 air data systems (copilot, pilot and IESI). You will need to set the pressure setting on all 3.</p>		
<p><b>Lighting Panel (Center Console)</b></p>	<p>Generally position lights (POS) should be on anytime the</p>		

13. POS and ACOL Lights ..... AS REQUIRED 14. SIGNS ..... AS REQUIRED 15. EMER EXIT ..... ARMED 16. Cockpit Lighting .....AS REQUIRED	battery is on. Red ACOL shall be used prior to engine start to warn any nearby personnel. White ACOL shall normally be used in flight.
<b>Forward Center Console</b> 17. FLOATS (If Installed) ..... OFF 18. WIPERS ..... AS REQUIRED 19. HTAWS ..... ON  <b>Weather Radar Control Panel (Rear Center Console)</b> 20. WXR (if required)..... TEST and then STBY	Note: currently prior to starting engines, the weather radar can only be activated by using the SHED OVER switch (in the pilot footwell area).
<b>MFD (DMAP page)</b> 21. DMAP ..... CHECK or AS REQUIRED <b>MFD (VMS page)</b> 22. VMS MAIN page ..... CHECK parameters validity 23. VMS SYST page ..... CHECK equipment status 24. VMS WEIGHT data ..... ENTER and (VAL)IDATE 25. Engine oil levels and temperatures ..... CHECK	Entering weight data will SET the aircraft payload (similar to using the MSFS payload menu). The payload menu may alternatively be used and the VMS WEIGHT Page will reflect accurate payload information.
26. OEI Rating Selection..... CHECK	You can access the OEI HI/LO selector on the tablet autopilot panel (expanded section), or by binding the hotkeys. You can't click on our collective OEI HI/LO button (as it would be difficult anyway)
Flight Controls Check - To be performed once per day. <b>Overhead Panel</b> 27. AUX PUMP ..... ON 28. Cyclic stick (longitudinal & lateral) ..... FREE TRAVEL 29. Collective pitch ..... FREE TRAVEL 30. Pedals ..... FREE TRAVEL 31. Cyclic, Pedals ..... CENTER 32. Collective ..... DOWN 33. AUX PUMP ..... OFF	Stick forces are not simulated unless using Force Feedback controllers, but you can still check your controls have free travel. Auxiliary hydraulic pump (electric) is required for testing the flight controls. It is not needed during flight.

**Engine Start Procedure**

This checklist will start the first engine. You can pick to start engine 2 or 1 first

<b>Inboard Pilot MFD (MFD4)</b> 1. VMS page (MFD4) ..... SELECT <b>Overhead Panel</b> 2. ENG1 and/or ENG2 ..... IDLE <b>Inboard Pilot MFD (MFD4)</b> 3. <b>START</b> ..... CHECK 4. N1 and TOT ..... MONITOR 5. Rotor spinning ..... BEFORE N1 > 25% 6. <b>START</b> ..... Disengaged at ~60% N1 7. N2 and NR ..... OBSERVE acceleration 8. TRQ ..... Increases 9. HYD Pressure ..... Increases 10. MGB Pressure ..... Increases 11. NR ..... CHECK stabilized 80% <b>Center Console</b> 12. ECS (climate control) ..... AS REQUIRED	Note: H160 has dual batteries (one for each engine) and therefore Airbus allows both engines to be switched to IDLE simultaneously.
---	---

This checklist will start the second engine after the first is already running.

<b>Overhead Panel</b> 1. ENG1 or ENG2 ..... IDLE <b>Inboard Pilot MFD</b> 2. <b>START</b> ..... CHECK 3. N1 and TOT ..... MONITOR 5. <b>START</b> ..... Disengaged at ~60% N1 6. N2 (1 & 2) and NR ..... OBSERVE synchronization	
--	--

This checklist must be run directly after starting the second engine

<b>Overhead Panel</b> 1. DC GPU (if coupled) ..... PRESS (DISCONNECT) 2. GPU DOOR .....CHECK 3. FLOATS (if installed) .....AUTO or AS REQUIRED 6. N2 (1 & 2) and NR ..... OBSERVE synchronization	NOTE: GPU DOOR is not simulated yet.
---	--------------------------------------

### AFCS Pre-Flight Test

The pre-flight test should be run on the first flight of the day.

1. COLLECTIVE PITCH ..... MINIMUM 2. Cyclic Stick and Pedals ..... HANDS OFF and FEET OFF <b>Autopilot Control Panel</b> 7. A. TRIM, AP1, AP2, BKUP ..... ON <b>Overhead Panel</b> 3. TEST switch ..... PRE-FLT 4. P-FLT TST on message list ..... CHECK 5. P-FLT TST OK on message list ..... CHECK 6. AFCS ..... OFF (fast cut) then ON	To fast-cut the AFCS, use <b>AP/BKUP CUT</b> (twice) and then <b>AP/BKUP ON</b> , or use the APCP and manually click AP1, AP2, and BKUP.  <p style="text-align: center;"><b>APCP Status</b></p> <table border="1" style="margin-left: auto; margin-right: auto;"> <tr> <td style="text-align: center;"><b>OFF</b> System Off</td> <td style="text-align: center;"><b>OFF</b> System On</td> </tr> </table>	<b>OFF</b> System Off	<b>OFF</b> System On
<b>OFF</b> System Off	<b>OFF</b> System On		

### Taxiing

This checklist is to be run after both engines are started and before takeoff. If taxi is not needed, this checklist still must be completed through step 6.

<b>Overhead Panel</b> 1. ENG1 and ENG2 ..... FLIGHT (guarded) 2. Message list ..... CHECK 3. Inboard Pilot MFD format ..... AS REQUIRED 4. Landing Lights ..... AS REQUIRED <b>Forward Center Console</b> 5. NOSE WHEEL ..... FREE 6. PARK BRAKE ..... OFF	Landing light control is on the collective (not usable - make a key binding or use the tablet lights panel).
<b>To Begin Taxi:</b> 7. Collective pitch ..... INCREASE (as necessary) 8. Cyclic Stick ..... ADJUST (forward and into the wind) 9. Collective pitch ..... ADJUST (to maintain speed) 10. Pedals ..... USE for turning <b>Stopping:</b> 11. Collective pitch ..... REDUCE to MINIMUM 12. Wheel Brakes ..... APPLY gradually 13. Cyclic Stick ..... NEUTRAL position	Minimal cyclic and collective should be used for ground taxi.  Expect to use between FLI 1.5-2.5 depending on weight.

### Before Takeoff

1. Flight Performance (VMS) ..... COMPUTED <b>Forward Center Console</b> 2. PARK BRAKE ..... AS REQUIRED 3. AFCS UPPER MODES ..... PREPARED (AS REQUIRED) 4. DA, DH, Baro setting ..... CHECK 5. Transponder ..... CHECK 6. Floats (if installed) ..... AUTO 7. Message list ..... CHECK	Check WEIGHT & PERFORMANCE to determine suitability for use of OEI ratings of capability of CAT A takeoff.
---	--

### Takeoff - Clear Area CAT A

This is a takeoff option checklist for ground level with no obstructions. If an engine were to fail at a critical time, rejection would result in landing (e.g. on the runway in front of you).

1. Hover (IGE) at 6ft, into the wind ..... PERFORM 2. Attitude ..... NOSE DOWN approx 10 degrees 3. IAS ..... INCREASE to VY When height is > 100ft 4. Collective pitch ..... MAX CONTINUOUS POWER <b>Forward Center Console</b> 5. L/G ..... UP	IGE: In ground effect
--	-----------------------

### Takeoff - Ground Helipad CAT A

This procedure can be used to engage a rearward or vertical profile takeoff with assistance from the AFCS to maintain trajectory. These are VFR procedures that do not reduce the minimums but rather support the pilot and reduce workload.

1. PARK BRAKE ..... ON 2. NR HI ..... ON 3. DA, DH, Baro setting ..... SET 4. HOV subformat (FND page) ..... SELECT 5. T/O mode (FND page) ..... SELECT 6. HELIPAD TAKEOFF or	NR HI switch is between the engine start switches on the overhead panel. It engages rotor rpm of 105%.  HOV subformat has the brown ground-speed lines (under the HSI/SCT/HOV button).
--	--

<p><b>VERTICAL TAKEOFF</b> ..... CHECK</p> <p>7. T/O TDP (FND page) ..... SELECT</p> <p>8. Hover (IGE) at 6ft, into the wind ..... PERFORM</p> <p>9. AP/GTC ..... PRESS TWICE</p> <p>10. <b>HEIGHT</b> and <b>HOVER</b> ..... CHECK</p> <p>11. GO AROUND ..... PRESS (engage procedure)</p> <p>12. <b>HELIPAD TAKEOFF</b> or <b>VERTICAL TAKEOFF</b> ..... CHECK</p> <p><b>If an engine fails before TDP</b></p> <p>13. <b>REJECTED</b> ..... CHECK</p> <p>14. Aircraft descent trajectory ..... MANAGE if needed</p> <p><b>If an engine fails after TDP</b></p> <p>15. <b>CONTINUED TAKEOFF</b> .....CHECK</p> <p><b>At the TDP</b></p> <p>16. GO AROUND ..... PRESS (engage Fly-Away)</p> <p>17. <b>GO AROUND</b> ..... CHECK</p> <p><b>At VY</b></p> <p>18. NR HI OFF ..... CHECK</p> <p>19. PARK BRAKE ..... OFF</p> <p>20. L/G ..... UP</p>	<p>Select the TDP (Takeoff decision point) using the MFD knob. Wait a few seconds to stabilize hover.</p> <p>The GO AROUND command is available as a key binding and also on the tablet autopilot panel.</p> <p>IFR flight is possible from the TDP onward.</p> <p>Be advised that after touchdown, your collective will become active again so you should lower it during the REJECTED segment. You may also use Collective Trim Release to intervene and cushion the landing</p>
--	--

**Climb**

This checklist is to be used after any takeoff procedure is performed.

<p>1. Collective pitch ..... MAX CONTINUOUS POWER</p> <p>2. Recommended climb speed .....VY</p> <p>3. AFCS UPPER MODES ..... AS REQUIRED</p> <p>4. DA, DH, Baro setting ..... CHECK</p> <p>5. Landing Lights ..... OFF</p> <p><b>Lighting Panel (Center Console)</b></p> <p>6. SIGNS .....AS REQUIRED</p>	<p>VY is about 65 kt and visible on the airspeed tape.</p> <p>Landing light control is on the collective (not usable - make a key binding or use the tablet lights panel).</p>
---	--

**Level Flight**

This checklist is to be used during the cruise portion of the flight.

<p>1. AFCS UPPER MODES ..... AS REQUIRED</p> <p>2. DA, DH, Baro setting ..... ADJUST</p> <p>3. Fuel Quantity ..... CHECK</p> <p>4. Navigation, Radios ..... AS REQUIRED</p>	
---	--

**Descent**

This checklist is to be used after the cruise portion of the flight.

<p>1. SIGNS .....AS REQUIRED</p> <p>2. AFCS UPPER MODES ..... AS REQUIRED</p> <p>3. DA, DH, Baro setting ..... ADJUST</p> <p>4. FLI ..... CHECK above desync lines</p> <p>5. IAS ..... AS REQUIRED</p>	<p>The FLI desync lines are at FLI 2.5 and they are two horizontal white lines. This point on the FLI signifies where the rotor may begin autorotation and it is best to maintain the collective above this point.</p>
--	--

**Before Landing**

This checklist is to be used before landing.

<p><b>Forward Center Console</b></p> <p>1. L/G ..... DOWN (3 green lights)</p> <p>2. NOSE WHEEL ..... AS REQUIRED</p> <p>3. PARK BRAKE ..... AS REQUIRED</p> <p>4. DA, DH, Baro setting ..... CHECK</p> <p>5. Landing Lights ..... ON</p> <p><b>Lighting Panel (Center Console)</b></p> <p>6. SIGNS .....AS REQUIRED</p> <p>7. ANTICOL ..... ON (color as required)</p>	
---	--

### Landing - Standard (Level surface)

This checklist is to be used for a standard landing on a reasonably level surface like an airport or helipad.

<ol style="list-style-type: none"> <li>1. IAS ..... 50kt</li> <li>2. Rate of Descent ..... approx. -500fpm</li> <li><b>When at 50ft</b></li> <li>3. IAS ..... REDUCE continuously</li> <li><b>Before touchdown</b></li> <li>4. Attitude ..... NOSE UP to stop the helicopter</li> <li>5. HOVER at 6ft ..... PERFORM</li> <li>6. Collective pitch ..... REDUCE</li> <li><b>When on ground</b></li> <li>7. Collective pitch ..... MINIMUM</li> </ol>	
--	--

### Landing – Sloped

This procedure is to be used when landing on a slope.

<ol style="list-style-type: none"> <li>1. PARK BRAKE ..... ON</li> <li>2. NOSE WHEEL ..... LOCK</li> <li>3. HOVER at 6ft ..... PERFORM</li> <li>4. Collective pitch ..... GRADUALLY REDUCE</li> <li>5. Cyclic stick ..... USE to prevent rolling</li> <li><b>When all wheels are on the ground</b></li> <li>6. Collective pitch ..... MINIMUM</li> <li>7. Cyclic stick ..... CENTER</li> </ol>	Respect sloped landing limitations.
--	-------------------------------------

### Shutdown

This checklist shuts down the engines and removes power from the aircraft. It is the last checklist as the aircraft will subsequently be Cold & Dark.

<ol style="list-style-type: none"> <li>1. PARK BRAKE ..... ON</li> <li>2. Collective pitch ..... MINIMUM</li> <li>3. Cyclic stick and pedals ..... CENTER</li> <li>4. ENG1, ENG2 ..... IDLE</li> <li>5. Floats (if installed) ..... OFF</li> <li>6. RA1, RA2 ..... OFF</li> <li>7. ECS ..... OFF</li> <li><b>After 30 seconds cooldown</b></li> <li>8. ENG1, ENG2 ..... OFF</li> <li>9. Rotor brake ..... APPLY when NR &lt; 50%</li> <li><b>After the rotor stops</b></li> <li>10. Rotor brake ..... RELEASE</li> <li>11. Flight Report (VMS) ..... CHECK</li> <li>12. Lighting (external, cockpit, emergency) ..... OFF</li> <li>13. <b>DOWNLOAD COMPLETE</b> ..... CHECK</li> <li>14. BAT1, BAT2 ..... OFF</li> <li>15 All switches ..... OFF</li> </ol>	Rotor brake handle is in the center of the overhead area
---	--

# Systems

## Cockpit Arrangement



1. Co-pilot MFD (MFD1)
2. Left Center MFD (MFD3)
3. Right Center MFD (MFD4)
4. Pilot MFD (MFD2)
5. Float
6. Windshield Wiper
7. HTAWS
8. ACAS Mute
9. Wheel
10. Standby instruments (IESI)
11. Cellphone
12. Auto-pilot control panel (APCP)
13. Cabin air control panel
14. CoPilot Flight Management
15. Pilot Flight Management
16. Audio Control Unit ACU6100 (inop)
17. Audio Control Unit ACU6100 (inop)
18. TFM-138B Radio
19. Lights panel
20. Weather Radar control panel (WXRCP)
21. Emergency Locator Transmitter
22. Cabin Lights (Copilot, Pilot)
23. Maintenance panel
24. Co-pilot control panel
25. Pilot control panel
26. Cabin light



## MFDs

Each MFD has 6 buttons on each side (top, right, bottom, left). When the button has a function, text will be shown on the MFD display directly adjacent to the physical button.

The buttons along the top of each MFD operate the main pages which the display can show.

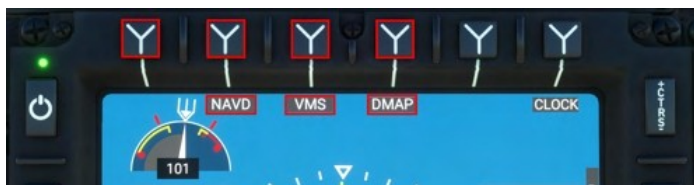

Each MFD also has buttons to adjust the intensity of the various layers:

- LUM: Overall display luminance
- CTRS: Weather and Terrain overlay intensity
- BRT: SVS and DMAP underlay intensity

Page Name	Function
FND: Flight and navigation display	Top: PFD (Primary Flight display) Middle: Navigation Bottom: Aircraft (Message list, fuel)
NAVD: Navigation display	Navigation information, route display, map overlays (terrain, weather, topo)
VMS: Vehicle Management Systems	Aircraft and systems information
DMAP: Digital Map System	Map information streamed from online service
MISC: Miscellaneous	Used for display of auxiliary cameras
EFB: Electronic Flight Bag	Used for offline and online EFB functions. <b>Not Installed.</b>

**Note:** When using ConfigTool or H:Events the MFDs are identified by the numbers, 1, 2, 3 and 4. The pilot MFD is 2, the center right MFD is 4, the center left MFD is 3 and the copilot MFD is 1.

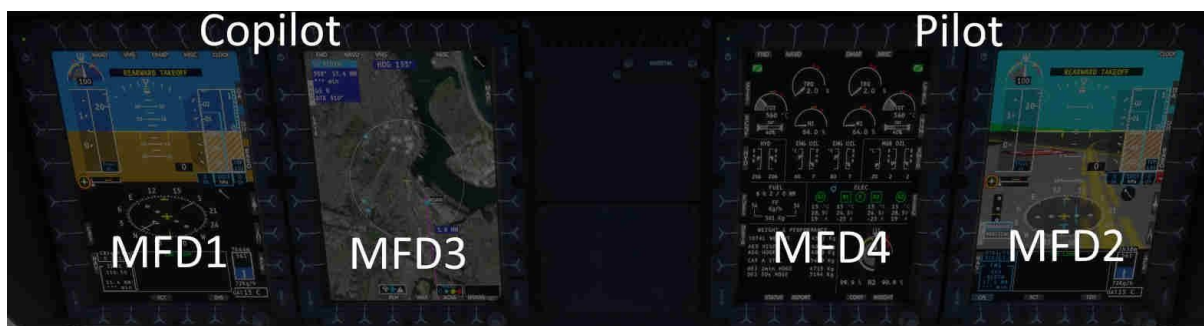

**FND Page**

Flight and Navigation Display

1. MFD Power
2. Stopwatch / Clock
3. CTRS – Overlay intensity (WXR,HTAWS)
4. Rotor gauge
5. AFCS Collective Axis status
6. AFCS Roll/Yaw Axis status
7. AFCS Pitch Axis status
8. AFCS AP Main status
9. Slip/Skid indicator
10. Decision Altitude (DA)
11. First Limit Indicator (FLI)
12. Airspeed indicator
13. Barometric altitude indicator
14. Radio altitude indicator
15. Decision Height (DH)
16. Below DA Alert
17. Below DH Alert
18. Takeoff Safety Speed (VTOSS)
19. Radio altitude (digital)
20. Kohlman Setting (Baro)
21. Mast Moment indicator
22. Wind indicator
23. Bearing 1 selector
24. Horizontal situation indicator
25. NAV Course selection
26. Bearing 2 selector
27. Cycle navigation source
28. Message list
29. Fuel gauge
30. Acknowledge new messages
31. LUM - Overall display brightness
32. Couple/Decouple AP nav source
33. Change views (HSI/SCT/HOV) – HSI, Sector, Hover views
34. Outside air temperature indicator
35. BRT – Underlay brightness (SVS, DMAP)
36. MFD Knob with push function
37. SVS warning (TAS > 200ktn)
38. Messages from GTN 750 or CMA9000 available

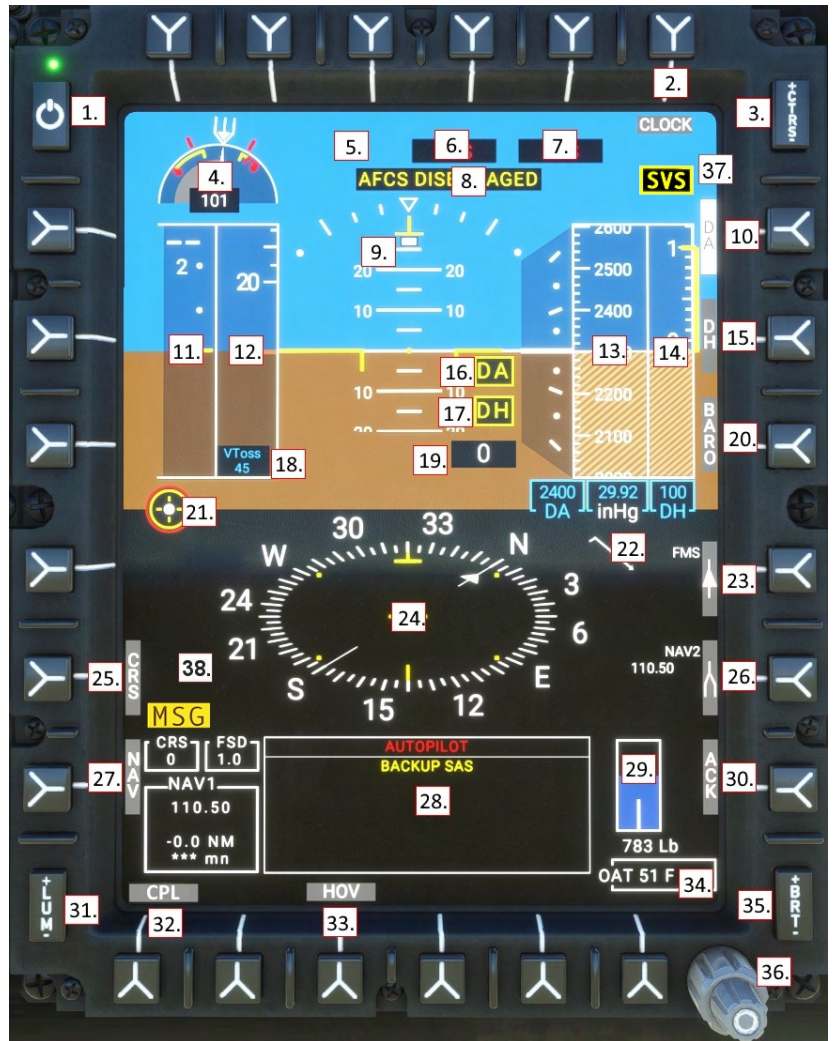

**First Limit Indicator (FLI)**

The FLI is presented on the FND page and communicates to the pilot the combined power-plant limits: Engine/MGB torque (TRQ), Engine N1 compressor speed (N1), and Engine turbine output temperature (TOT). The background of the FLI tape is the collective position, from 0 degrees pitch to 10 degrees.

When exceeding limits, you should expect the NR to fall (if N1 capability is exceeded) and excessive torque will cause engine wear and MGB damage. Except in failure, the FADEC will not exceed N1 or TOT limits.



**All Engines Operative (AEO)**

When all engines are operative, the FLI indicates the power limits, usually based entirely on torque. The pilot should take care to avoid exceeding the transient power limit (1), use of the range between the maximum power limit (2) and transient power limit (1) is permitted only for unintended use, up to 2 seconds. The blue line (4) indicates the amount of power which will be immediately available should an engine fail. If the current collective position is above the blue line and an engine should fail, the pilot would immediately need to lower the collective otherwise rotor RPM would begin to decay. The takeoff power limit (3) is available for 30 minutes, and then collective power should be reduced to maximum continuous power (bottom of (3)). The power rating timer (10) will be visible 90 seconds prior to 30 minutes elapsing

1. Transient power limit (teardrop)
2. Maximum power limit
3. Takeoff power (30 minutes)
4. OEI power limit
5. Current power setting

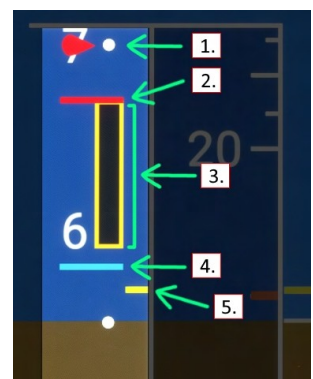

**One-Engine-Inoperative (OEI)**

The FLI will clearly indicate the OEI status (6) and show the power limits available. Using the OEI HI/LO button, the pilot may switch between use of the 30 second and 2 minute OEI power bands. When collective position exceeds the capability of the engine, the rotor rpm will drop.

- 6. OEI (One Engine Inoperative) flag
- 7. Topping signal (FADEC limit)
- 8. 30 second OEI power rating
- 9. 2 minute OEI power rating
- 10. Power rating timer

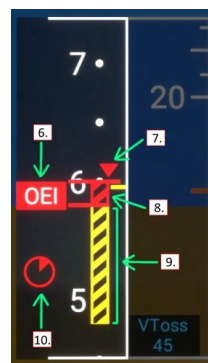

**Airspeed indicator**

- 1. VNE (velocity never-exceed speed, airframe limit). This is calculated based on your weight, outside air temp and pressure altitude. It will slide up and down based on those factors
- 2. GPS Ground Speed (this is intended to be shown as a digital value if it is off-scale, but I didn't do that)
- 3. VNE Power Off (velocity never-exceed speed while in autorotation). This is the same as above, calculated from charts and intended to be used should both engines fail
- 4. Current airspeed (IAS)
- 5. Speed bug
- 6. VY (Best climb speed)
- 7. Not shown: VTOSS (Takeoff Safety Speed) at 45kt. This is a minimum takeoff speed for engine failure
- 8. Not shown: CHK VNE (Check VNE speed). Occurs when avionics cannot calculate VNE

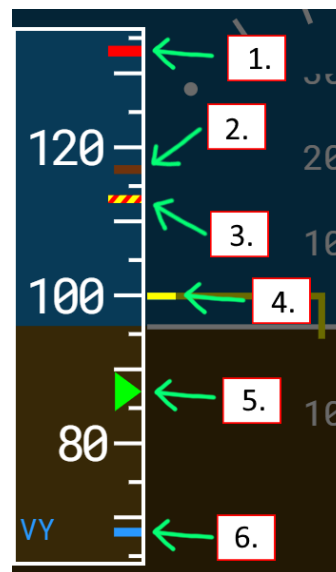

**Stopwatch (chronometer)**

Use the CLOCK sk to cycle between local time, stopwatch and off. In Stopwatch mode, use the MFD knob push function as follows.

- First short press starts the stopwatch
- Second short press stops the stopwatch
- Long press while stopwatch is running resets and restarts stopwatch
- Long press when stopwatch is not running resets stopwatch



**Set altimeter (BARO)**

There are 3 altimeters in H160 (pilot, copilot and IES1). Change the MFD altimeter setting (kohlman setting) with this procedure:

- 1. Select the BARO key, the BARO text will illuminate white in reverse video.
- 2. Turn the MFD knob to increase or decrease the current altimeter setting. Press the knob for STD/1013/29.92.
- 3. Select the BARO key again to exit the mode

NOTE: Change units between in/hg and hpa in the tablet aircraft app.

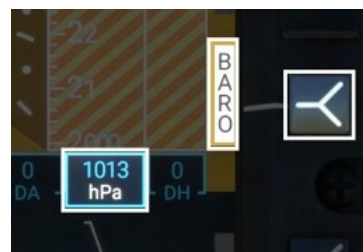

**HSI View**

HSI mode displays a navigation source and deviation range.



**SCT (Sector) View**

Sector mode displays a 60 degree situation view with the flight plan line and navigation source as well as weather radar.

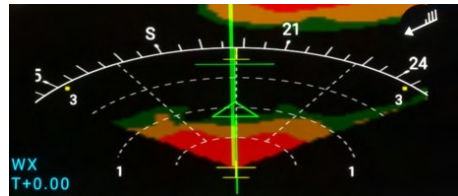

**HOV (Hover) View**

Hover mode provides brown GPS-based ground-speed lines which can be used to hover precisely without suitable ground reference. Hover mode is also useful in GTC mode as it displays the green digits corresponding to the current trends that the GTC mode is maintaining.



**SVS (Synthetic vision)**





The PFD will operate in both FDS (blue sky, brown ground) and SVS mode which enables a synthetic vision background. Note that in SVS mode the pitch scale is compressed in FDS mode and expanded to 1:1 scale in SVS mode. SVS is available on all 3 MFDs and may be combined with all other modes.



**Wind indicator**

The wind indicator is shown on both the FND and NAVD pages.

- Each long feather is 10kt
- Each short feather is 5kt
- The triangle is 50kt
- The circle is wind calm.

	Wind calm
	Wind 25kt
	Wind 50kt
	Wind 75kt

## NAVD Page

Navigation Display

1. NAV sk - change nav source (NAV1, NAV2, GPS/FMS)
2. Next waypoint information
3. Ground Speed and True Airspeed
4. MAP sk - toggles the hill shading layer
5. RNG sk - map range (use the knob to control range)
6. Bearing 1 sk - Cycle bearing 1 (NAV1, GPS, hidden)
7. Bearing 2 sk - Cycle bearing 2 (NAV2, GPS, hidden)
8. FMS destination time and fuel estimation
9. Bearing frequency, distance and identifier
10. FMS waypoint and destination information
11. DATA sk - Show information on all nav sources
12. CPL/DCPL couples the AFCS to the selected navigation source
13. SCT/ROS/PLN sk - ROSE or SECTOR or PLAN view
14. WXR sk - Toggle weather overlay. (FAIL and STBY indicate WXR panel switch position)
15. HTAWS sk - Toggle terrain aware overlay (green/red)

Note: To see the traffic (ACAS), activate the transponder on GTN-750 or CMA9000.

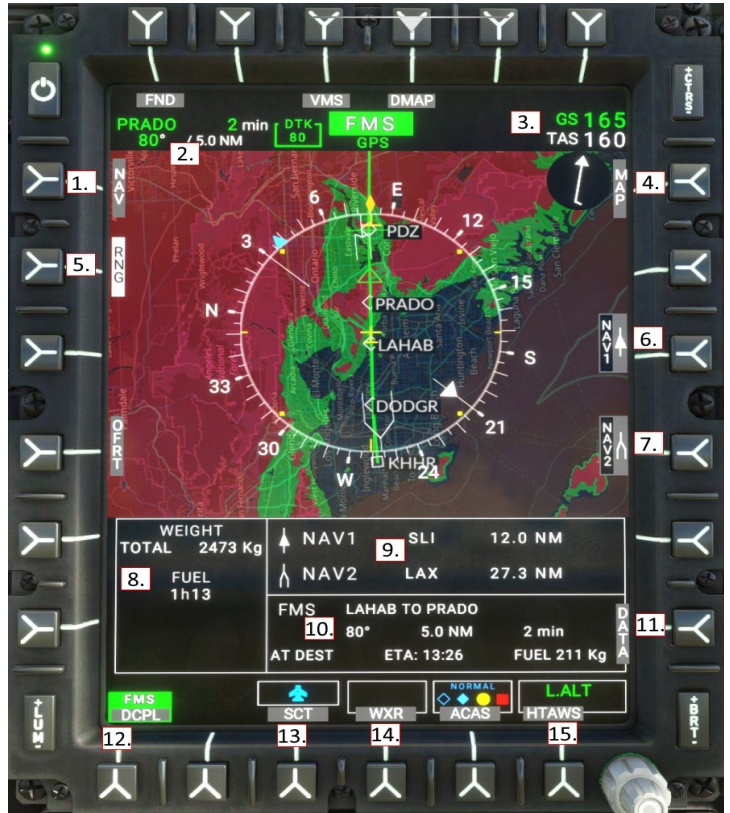

## NAVD Page (DATA subformat)

The DATA select key will reveal information regarding all installed navigation sources.



## NAVD Page (Sector view)

Sector view provides a 60 degree situation view in front of the aircraft.

The other views are

ROS: (Rose) - A 360 degree situation view with the aircraft heading oriented upward.

PLN: (Plan) - A 360 degree situation view with North oriented upward



**VMS Page**

Vehicle Management Systems

1. Engine low pressure bleed valve status
2. Engine main status (IDLE, START, FAIL)
3. Engine Torque
4. Engine exhaust temperature
5. Engine N1 compressor
6. Inlet Barrier Filter status
7. Hydraulic System 1 and 2 pressure
8. Engine oil temperature and pressure
9. Main Gearbox oil pressure (system 1 and 2) and oil temperature
10. Endurance (based on present fuel flow)
11. Fuel (center feeds into left and right supply tanks)
12. Engine generator 1 status
13. Main battery status
14. Engine generator 2 status
15. Rotor rpm gauge (and N2 for engine 1 and 2)
16. N2 for engines 1 and 2
17. SYST sk - System page
18. RCNF sk - Reconfigure page
19. NUM sk - reveal nominal digital values
20. DATA sk - Switch between timezone, performance, hoist, and cargo hook subformats
21. REPORT sk - Switch to flight report subformat
22. CONF sk - Switch to aircraft config subformat
23. WEIGHT sk - Switch to weight subformat
24. CTRL sk - Switch to control page
25. XMSN sk - Switch to XMSN page
26. ELEC sk - Switch to electric page
27. HYD sk - Switch to hydraulic page
28. FUEL sk - Switch to fuel page
29. STATUS sk - Switch to status subformat

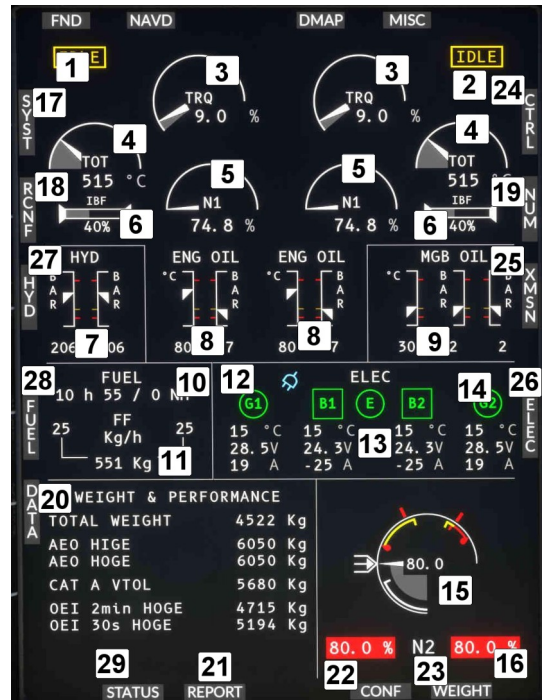

The top section of the VMS page displays the main format, and the bottom section displays the subformat.

**VMS Page - Engine indications**

Starting engine (starting limits)	TOT limits: Max: 800C Transient: 850C  Transient starting TOT is allowable for up to 10 seconds.	
Engine idle (no limits)	IDLE detent is to be used for starting, ground operations, and cool-down after flight.  No limits are applied when the engine is in IDLE.	
Two engines in FLIGHT (AEO limits)	Note the presence of the amber takeoff power band on all three Torque, TOT and N1.  <b>NOTE:</b> Limits are computed and will vary based on pressure altitude and outside air temperature.	
Takeoff power (TOP) (AEO limits)	The amber band is takeoff power and is available for 30 total minutes per flight.  A white timer will be displayed when 90 seconds are remaining.  After 30 minutes power should be reduced to maximum continuous.	
Transient exceedance (AEO limits)	Transient power is available for <b>unintended</b> use for up to 12 seconds. A gong sound will play at the beginning of each exceedance.	

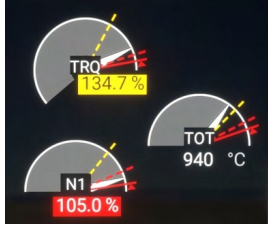
<p>FADEC Failure (no limits)</p>	<p>Level 3 FADEC failure -Fuel valve is frozen and the engine cannot respond to commands to change the N1.</p> <p>Use FADEC EMER to attempt recovery to level 2 FADEC failure.</p>	
<p>One engine in flight (OEI limits)</p>	<p>OEI (one engine operative) limits are displayed as lines. Note that the OEI limits are much higher than AEO limits.</p>	
<p>OEI - 2 minute rating</p>	<p>The amber band is the 2-minute power rating when only one engine is operative.</p>	
<p>OEI - 30 second rating</p>	<p>The red power band is the 30 second power rating.</p> <p>Note the red topping triangle (OEI HI and OEI LO) setting controls whether the FADEC will allow use of the 30 second rating or instead droop the NR when commanding more collective power.</p>	

**VMS Main Page (MAIN subformat)**

The main subformat contains two panels. The right panel is used for NR and N2 indications, and the left panel has a page controlled by the DATA select key.

DATA	<p><b>WEIGHT &amp; PERFORMANCE</b></p> <p>TOTAL WEIGHT 4500 Kg</p> <p>AEO HIGE 6050 Kg</p> <p>AEO HOGE 6050 Kg</p> <p>CAT A VTOL 5477 Kg</p> <p>OEI 2min HOGE 4673 Kg</p> <p>OEI 30s HOGE 5112 Kg</p>	 <p>102.1% N2 102.1%</p>
------	---	---

NR is shown for both engines in percent, managed automatically. If you run out of engine power, NR will start to drop. To recover NR you should lower the collective, which lowers the angle of attack of your rotor blades, which lowers the air resistance acting on blades, thus making engine power required less, allowing the engine to speed up the rotor back to 100%.

Pressing the DATA key will cycle through

<p>WEIGHT &amp; PERFORMANCE</p>	<p>Aircraft weight and estimations on performance margins</p>	
---------------------------------	---	---

<p>TIME ZONE</p>	<p>Displays the current sim time zone and current local time</p>	
------------------	--	---

**VMS Main Page (STATUS subformat)**

The Status page displays information about the FADEC which is generally used by maintenance only.

FADEC 1		SYSTEM STATUS		FADEC 2	
1013	HPA	P0		1013	HPA
14.9	C°	T1		14.9	C°
5.1	%	CLP		5.1	%
102.1	%	N2		102.1	%
		N2 DATUM		102.0	%
14.9	C°	FUEL TEMP		14.9	C°
		MM		0	%

PREV REPORT CONF WEIGHT

**VMS Main Page (REPORT subformat)**

The Flight Report page displays information about the most recently conducted flight.

1/4		FLIGHT REPORT 20		VALIDATED	
BLOCK TIME:		0 h 29 mn			
FLIGHT TIME:		0 h 0 mn			
NEXT	FLT / CUM	CYCLES	FLT / CUM		
	1 / 5	N1	1 / 4		
	1 / 7	N2	1 / 5		

PREV STATUS CONF WEIGHT

**VMS Main Page (EPC subformat)**

The Engine Power Check page displays the interface to conduct an on ground or in flight power check.

EPC is not currently implemented.

**VMS Main Page (CONF subformat)**

The Configuration page displays information about the Helionix configuration which was loaded.

CONFIGURATION - SYSTEM	
AUXILIARY FUEL TANK	NOT INSTALLED
FUEL FLOW SENSOR	INSTALLED
ENGINE INLET FILTER	NOT INSTALLED
HOIST	NOT INSTALLED
CARGO HOOK	NOT INSTALLED
MASTMOMENT SYSTEM	LINEAR

PREV STATUS REPORT WEIGHT

**VMS Main Page (WEIGHT subformat)**

The Weight page is used to program the aircraft weights before flight.

Press VAL when finished to commit the weights.

WEIGHT COMPUTATION	
PAYLOAD	0 KG
CREW	155 KG
EMPTY EQUIPPED	3820 KG
TOTAL FUEL	560 KG
TOTAL	4530 KG

Use the **PUSH** function of the MFD knob, to advance the weight entry between PAYLOAD, CREW, and TOTAL FUEL entry lines. All items will be updated immediately when you spin the MFD knob. Both the small and large knobs are active, enabling large and small increments of both payload and fuel.

**NOTE:** Using the in-aircraft WEIGHT tool will not cause the MSFS weight dialog to update. The aircraft will be updated from changes to either location, but the changes are not reflected back in the MSFS weight dialog unless you only use that tool for weight entry. In any case the aircraft will show its accurate weight and fly using those numbers.

**VMS Page Flight Control**

This page shows the user inputs and the responses of the autopilot systems to them. It can be very helpful in troubleshooting.

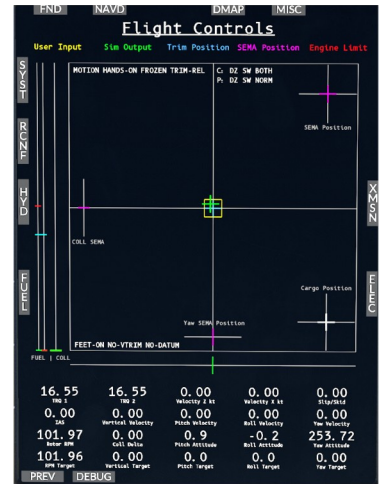

**VMS Page Electric**

The H160 has a 28V electrical system consisting primarily of:

- Aircraft main battery (x2)
- Combined Starter/Generator (x2)
- Separated Bus-Systems

The two sides of the aircraft are redundant and split into system 1 and system 2. Critical equipment is powered by both systems (ESS1/ESS2). Each system has a bus tie which allows the system to be isolated. Normally they are not isolated to allow sharing of electrical loads. When bus ties are closed, both systems can use power from the main battery or either generator.

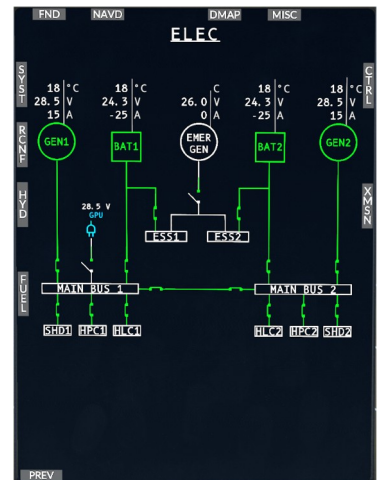

**VMS Page Fuel**

The H160 has a fuel system that consists of a front tank, an rear (Auxiliary) tank and two feeder tank connected tho the respective engine.

Fuel flows from the front tank and the rear tank into the two feeder tanks and from there into the engines.

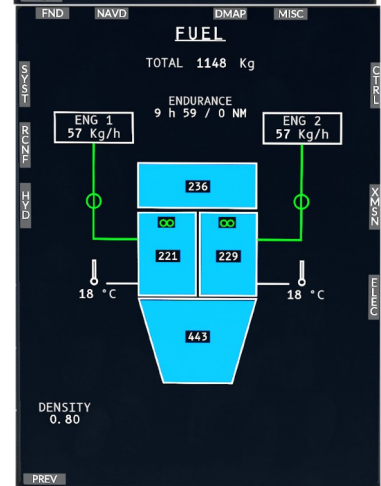

**VMS Page Hydraulic**

The hydraulic system has a redundant design. The actuators (3 for the main rotor, one for the tail rotor) are operated hydraulically and transmit the control commands to the rotors. The necessary operating pressure is provided via the auxiliary pump.

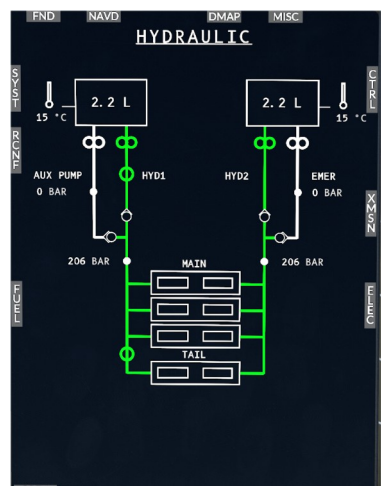

**VMS Page RCNF (Reconfigure format)**

The Reconfigure format is used to display information about the system configuration regarding the AHRS and ADC, Magnetometers and RA. The top of the page shows each MFD and which configuration it is currently using. The bottom of the page shows the individual sensors and their current readings.

SYST: Switch to the SYST/System VMS format  
 PREV: Switch to the main VMS format

Selective reconfiguration of sensors by the user is currently inoperative.

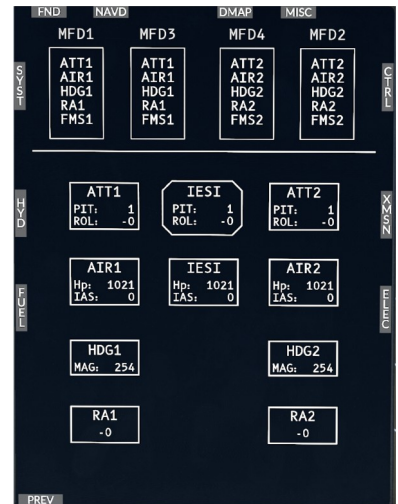

**VMS Page System (System format)**

The System page is used to display status on equipment connected to the aircraft (shown at the top) and on the AFCS system (shown at the bottom).

1. Equipment status area
2. AFCS status area
3. AFCS Trim actuator status
4. AFCS SEMA type actuator status
5. APCP (Control Panel), Collective control and Cyclic control status
6. AFCS system status
7. Return to main VMS format
8. Switch to RCNF (Reconfigure) VMS format

AFCS System Status legend:

- Green:** Active
- Cyan:** Standby
- Red:** Inoperative
- Gray:** Disabled by upstream fault

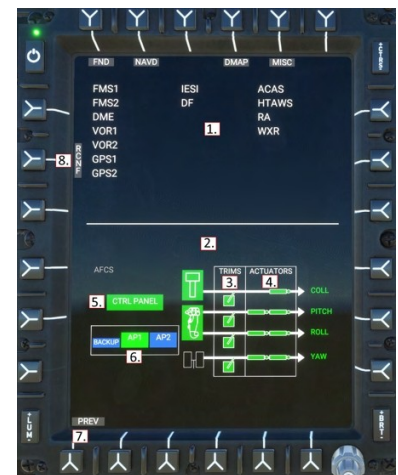

**VMS Page XMSN**

Two gearboxes transfer the power of the two turbines, via maingearbox, to the main rotor and, via tailgearbox (TGB), to the tail rotor.

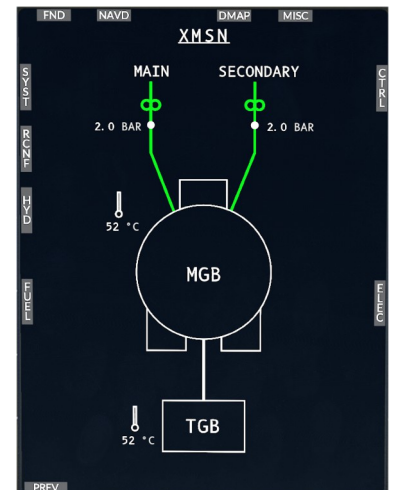

## DMAP Page

### Digital Map

1. LAYR sk - Toggle airspace visibility
2. Aircraft magnetic heading
3. MAP sk - Toggle between OSM and OpenTopoMap layers
4. PLN/ROS sk – Toggle between NorthUp and HeadingUp views
5. WXR sk - Toggle online weather overlay
6. Inop.
7. HTAWS sk – Toggle HTAWS height above terrain overlay

Use the MFD knob to control the range of the map.

Note: To see the traffic (ACAS), activate the transponder on GTN-750 or CMA9000.

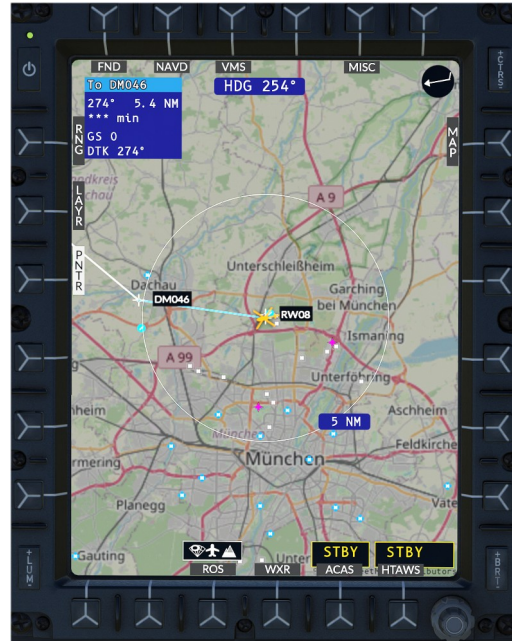

### Data Sources (Advanced)

The map data source is driven by slippy tile xyz sources in:  
 Community\hpg-airbus-h160\html\_ui\HPGH160-User\MFD\DMAP.json.

The API format is OpenLayers2 (not leaflet). See here for more providers:  
<http://leaflet-extras.github.io/leaflet-providers/preview>

## MISC Page

Miscellaneous, used for auxiliary camera sources. The MISC page is available on MFD1 (copilot), MFD3 (left center) and MFD4 (right center).

The tail boom camera is available on all variants. The camera itself is a view provided by MSFS and composed from the satellite imagery overlaid on the 3d synthetic vision viewport.

The select keys at the bottom for LOW and HIGH are mutually exclusive.

LOW (Default): Camera will not be updated with aircraft pitch and bank information.

HIGH: Camera will be updated with pitch and bank information, which appears to have a modest cost in sim performance but enables a more realistic view.

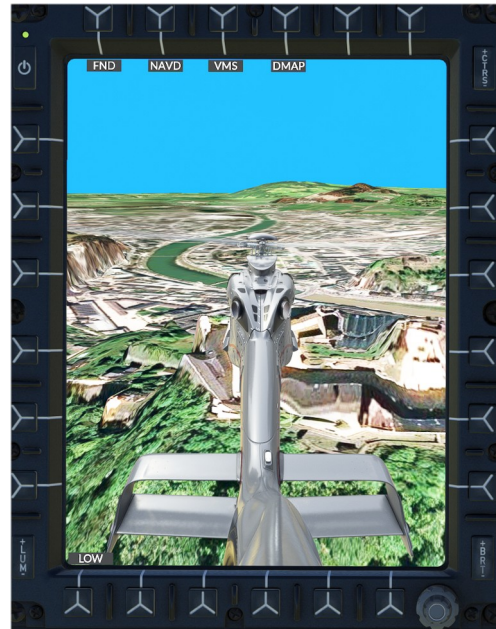
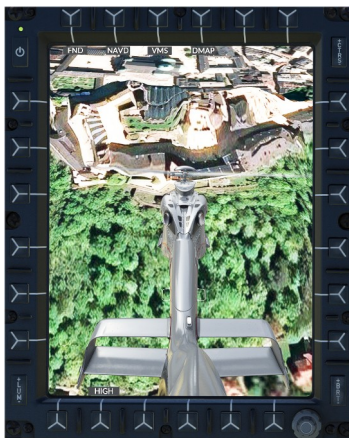

## Emergency Floats

The emergency flotation system installed permanently on the Luxury variants.

The system must first be armed using the switch on the overhead panel, and then it can be activated either automatically or when the pilot activates the **FILL FLOATS** function.

Access the fill floats and repack functions by clicking the top clock on the tablet and then clicking the button on the Emergency Floats notification in the list.



## Windshield Wiper

Control your wiper (off, slow, fast).  
Wash – not working



## Terrain Awareness and Warning System (HTAWS)

Helicopter Terrain Awareness System (HTAWS). It is based on local stored terrain data (/Community/hpg-htaws-data/). This must be installed separate (see pinned msg on Discord or at the Installation chapter below).

You may mute the aural warnings by selecting the overhead AUDIO/TAWS switch to STBY or MUTE.  
Starting with .82 the new terrain profile

You may also assign a binding in Hype Operations Center, to `HTAWS MUTE-FOR-5-MINS`, which is intended to be clicked shortly before landing.

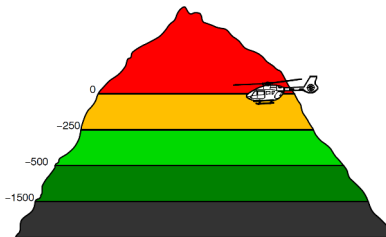

## Wheel

- 1 – Lock or unlock nose wheel (if locked **LOCK**)
- 2 – Status (up/down/park brake) (down **park** **park**)
- 3 – Switch wheel up/down
- 4 - inop
- 5 – Switch park brake (on/off)



## Standby instrument (IESI)

It is intended to serve as backup in case of a failure of the standard glass cockpit instrumentation, allowing pilots to continue to receive key flight-related information.



## Cellphone

The cellphone is an all-in-one cellular and satellite voice, data and tracking system. The H160 is always connected to the world via cellular networks and Iridium satellite.

Currently not working



## Cabin air control panel (GPCP)

The knob in the middle controls the cabin temperature.

Note: The H160 has no anti ice function. To simulate that, set the temperature to HIGH.



## Autopilot Control Panel

The Autopilot Control Panel (APCP) is used to control the autopilot systems. It is similar in nature to a Mode Control Panel from large airliners. The APCP is logically structured such that major systems are shown along the top row. Each is a push button which toggles the system on or off, as well as an illuminated OFF status. When OFF is displayed, the system may have been switched off by the pilot or the system may be inoperative due to a failure or lack of electrical power.



**A.TRIM** or AUTO TRIM is a system which controls the trim and feedback forces of the cyclic control. It allows the pilot to fly the helicopter hands-off and to intervene by using a CYCLIC TRIM RELEASE button or by manually pushing on the springs of the trim system, which either pauses or provides follow-up movement of the trim.

**BKUP** or BACKUP SAS is an independent system which provides only 3-axis basic stabilization. To remain on always, but only used in the event of AP1 and AP2 failure.

**AP1** and **AP2** are redundant autopilot systems, implemented in the aircraft management computers. These systems provide both basic stabilization (SAS) as well as UPPER MODES like HDG, NAV, ALT etc. When both systems are enabled, one will act as the primary and the other will operate in a standby mode, ready to take over if the primary system should fail. AP1 and AP2 require FMS (FMS 1 and FMS 2) to be switched to ON.

### Upper Modes

Each of the upper modes knobs has a push function which toggles the mode, as well as left and right turn which changes the bug or setpoint for that mode.

The VS/HDG butterfly knob switches between traditional (HDG and VS) and GPS (TRK and FPA) modes. When switched to GPS the VS mode will become FPA and the HDG mode will become TRK.

Collective modes below (CRHT, IAS, ALTA, VS/FPA) will have the 4-axis autopilot use the collective control, so engagement will prevent you controlling your collective axis, unless you hold COLLECTIVE TRIM RELEASE.



### Collective Modes

**CRHT** or Cruise Height works like an altitude hold, but uses the radio altimeter as the reference. This will result in a rough ride but enables the helicopter to traverse hilly terrain. This feature is designed for use over water. IAS or Indicated Airspeed works the same as a fixed-wing airspeed hold.

**IAS** or Indicated Airspeed works the same as a fixed-wing airspeed hold.

**ALTA** or Altitude Acquire. When you turn the knob the bug will move, but your aircraft will not change from the current mode (even if ALT is selected). This mode works as a way to allow a preselection for a new altitude, and then it will use the VS mode to move from your current altitude to the new altitude. Once at the new altitude, ALT mode will be automatically engaged and the new altitude will be held.

**VS/FPA** or Vertical Speed/Flight-Path-Angle works the same as a fixed-wing vertical speed hold. When in FPA mode the aircraft speed is taken into account, allowing a descent angle to be defined. Useful with the FPV (Flight Path Vector) available on the SVS (Synthetic vision) view.

### Roll/Yaw Modes

HDG/TRK or Heading/Track Hold works the same as fixed-wing heading hold, however it will use roll to accomplish the task at higher speeds, and yaw while in hover domain (under 30kt).

Track will consider the current wind and pick a heading that allows a straight line to be flown despite a crosswind.

### Modes not on the APCP

**NAV** or Navigation mode (as well as APP and V.APP) is engaged by selecting a navigation source on the pilot MFD (use the NAV softkey on the MFD to pick between GPS, NAV1 and NAV2. The CPL softkey to couple the source to the AP) GTC or Ground Trajectory Command mode is engaged by pressing AP/GTC binding or the Tablet autopilot panel.

**GTC.H** or Ground Trajectory Command in Hover submode is engaged by double-clicking **AP/GTC** binding or the Tablet autopilot panel.

**ATT** mode is automatically engaged in the absence of an upper mode on the axis.

**GA** or Go-Around mode is engaged when pressing the COLLECTIVE GA control

### Beep Trim

When any of the above modes are active, you will find that context-sensitive “beep trim” control is available. You can assign these to a hat, or click the buttons on the Tablet autopilot panel. These context sensitive modes will intelligently change the correct bug for the modes that are engaged. For example if you have ALT engaged, CYCLIC BEEP TRIM UP (and down) will control the altitude bug. If you were in VS mode, CYCLIC BEEP TRIM UP (and down) will control your vertical speed bug.

### Cyclic grip

The cyclic grip has these important controls:

Common Name <b>MSFS Binding</b>	
AP/BKUP ON <b>AUTOPILOT ON</b>	Press once: Engage <b>AP1, AP2, &amp; BKUP</b> Press twice: Select <b>ALT, HDG, &amp; IAS</b> .
AP/BKUP CUT <b>TOGGLE DISENGAGE AUTOPILOT</b>	Press once: Disengage <b>AP1</b> and <b>AP2</b> Press twice: Disengage <b>BKUP</b>
AP/UM OFF <b>AUTOPILOT OFF</b>	Press once: Cancel selected upper modes Hold for 2SEC: Clear preselections (bugs)
AP/GTC <b>TOGGLE AUTO HOVER</b>	Press once: Engage <b>GTC</b> Press twice: Engage <b>HOVER</b>
4-Way Cyclic Beep Trim <b>INCREASE ROTOR LONGITUDINAL TRIM</b> <b>DECREASE ROTOR LONGITUDINAL TRIM</b> <b>INCREASE ROTOR LATERAL TRIM</b> <b>DECREASE ROTOR LATERAL TRIM</b>	Contextual to the engaged AFCS modes.
Cyclic Trim Release <b>ROTOR TRIM RESET</b>	Pause the AFCS logic to take manual control, as well as communicating your intents to the AFCS.

### Collective grip

The collective grip has these important controls:

Common Name <b>MSFS Binding</b>	
COLLECTIVE GA <b>AUTO THROTTLE TO GA</b>	Engage <b>Go Around</b> mode
4-Way Collective Beep Trim <b>INCREASE AUTOPILOT N1 REFERENCE</b> <b>DECREASE AUTOPILOT N1 REFERENCE</b> <b>RUDDER TRIM LEFT</b> <b>RUDDER TRIM RIGHT</b>	Contextual to the engaged AFCS modes.

Additional ease-of-use controls are provided on the tablet, for those that can't bind all the functions directly to their controller.

### NPX138 FM Transceiver

The NPX138N FM transceiver from Canyon is designed as a stand-alone device for one-man use.

The product was developed in close cooperation with law enforcement agencies, emergency services and forestry authorities and solves common problems associated with complex multi-radio systems for aircraft in use.



Currently not working

## Weather Radar

Weather radar is available as an option in the civilian variant, and always available in the luxury variant. The exterior radome option and weather radar are installed and uninstalled together. You can select the radar option in the tablet aircraft app.

Weather radar is available on the FND and NAVD pages. The DMAP page and the tablet Maps app use an online weather service which works irrespective of the selected radome option.



The weather radar is controlled via the WXRCP panel on the center console. The main knob has 4 functions (OFF, Standby, TEST, and On). STBY mode is used when on the ground. TEST mode is used to display a test pattern on the FND and NAVD pages when weather has been selected.



Message	Meaning	Notes
<b>FAIL</b> or <b>WXR FAIL</b>	Weather radar is not detected electrically. Set the WXRCP knob to ON.	Radome must be installed for WXRCP to be visible on the center console.
<b>STBY</b> or <b>WXR STBY</b>	Weather radar is detected but in standby mode. Set the WXRCP knob to ON.	
<b>CHECK RANGE</b>	MFD4 and MFD2 range knobs must match, or WXR should be de-selected.	MFD1 has independent range.
<b>WXR TX INHIB</b>	Weather radar is automatically inhibited when less than 50FT RA to protect personnel.	Weather radar will become available automatically when crossing 50FT RA.

## Aircraft Lights

The H160 lights are configurable by the use in the tablet aircraft app. Lights are similar to the fixed wing operation. Lights are primarily controlled by the light section on the center console or you can bind an individual key on your stick.



## Cockpit lights

There are three cockpit lights available at the front of the overhead panel (Pilot, Center and Copilot). Click the light itself to activate. Cockpit lights are available when the master battery switch is ON or when the Ground Power switch is set to ON (not to be confused with External Power). When using Ground Power without the aircraft battery, the lights will be switched off after 10 minutes.

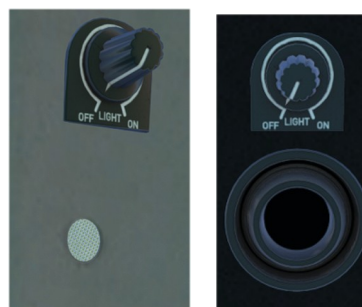

### Instrument Panel lights

Instrument panel lights are available in DAY, NIGHT and NVG modes. DAY mode switches the panel lights off, while NIGHT and NVG enable the integral (green) panel lights. Use the dimmer switch (8, above) to adjust the light intensity. DAY, NIGHT and NVG will also impact the base brightness for the MFDs.



### Exterior lights

1. Search and Landing (S/L) Light
2. Strobe (white) or Beacon (red) lights
3. Navigation/Position (POS) lights (left-red, right-green, rear-white)
4. Fenestron Safty light (LOGO)



### Emergency Locator Transmitter (ELT)

A radio beacon for marking the emergency position. As a rule, small radio transmitters are used with the help of which satellites or search and rescue teams can locate ships, people or aircraft in need of rescue.



### Maintenance panel

Switches all inop at the moment.



### Overhead Panel Copilot

1. Mission Selector (Currently inoperative)
2. Misc (Event Marker for FMS CMA9000)
3. Cargo (Currently inoperative)
4. FMS Load Selector (Select active FMS)
5. FMS Main Switch (Activate Flight Management System 1/2)
6. Radar Altitude 1/2 (RA)
7. OEI Training Mode (Currently inoperative)
8. Hydraulic (Currently inoperative)
9. Test (Currently inoperative)



## Overhead Panel Pilot

The Engine Control Panel (ECP) is used to start and stop the engines as well as operate additional functions for emergency or abnormal procedures.

1. Emergency Generator (On/Off)
2. Ground Power DC
3. Emergency Cut-Off (Gen 1/2 )
4. Generator 1 and Battery 1
5. Generator 2 and Battery 2
6. IFB 1/2
7. Engine 1
8. Chip Burning
9. NR High
10. Engine 2

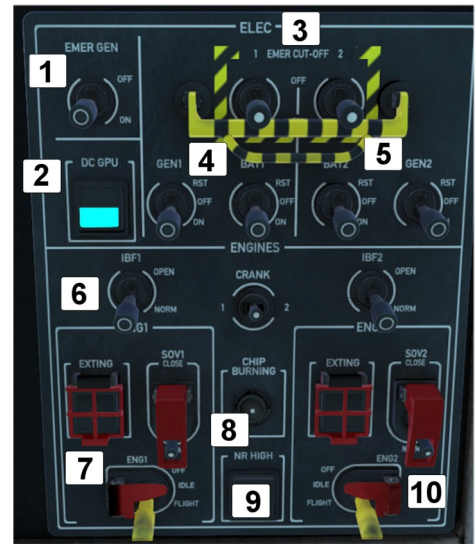

The Engine Main switch may be placed into 3 detents: OFF, IDLE and FLIGHT. The IDLE detent is used for starting the engine and for cooldown after flight, it will not raise the rotor RPM to 100%. The FLIGHT detent is to be selected prior to takeoff and until after landing. The OFF detent will close the fuel valve and trigger an engine shutdown. When in the FLIGHT position, the engine main switches should be latched.

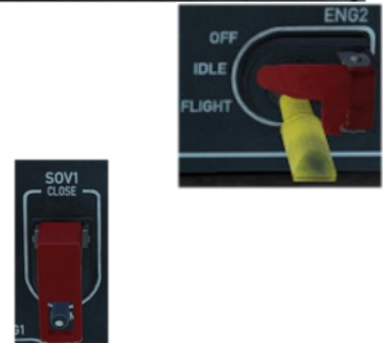

Fuel pump can be switched off with SOV1/2 switch. Watch VMS Subpage Fuel.

Clogging levels may be controlled in the Failure & Maintenance app. Clogging is disabled when the Aircraft Damage is set to Off in the Aircraft app on the setup page.

Generator switches may be used to isolate a malfunctioning generator from the rest of the aircraft. They shall remain in ON unless directed by a checklist.

Battery switches may be used to isolate batteries from the rest of the aircraft. They shall remain ON unless directed by a checklist. To shut down the aircraft switch to OFF.

## External Power

The tablet may be used to connect and disconnect external power. An icon will be displayed in the notification bar if the external power unit is available or connected. A message in the notification list may be used to CONNECT and DISCONNECT external power.

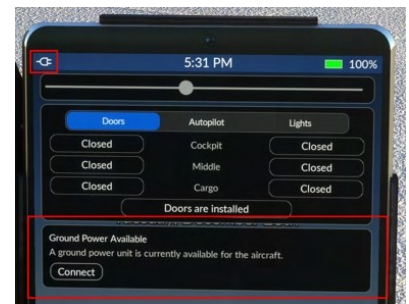

## Engine Filters (IBF)

Inlet Barrier Filters protect the engine from abrasive sand causing excessive wear on the engines. The filters block sand and dirt but will eventually become clogged which will reduce engine performance. The pilot may control the operation of the bypass doors, which allow a way for air to directly reach the engine, bypassing the filters. It's best to keep the IBF system in the NORM position unless operations require otherwise. **Clogging over 100% will reduce engine performance.**

**OPEN:** Bypass doors are open and the engines are directly exposed to outside conditions.

**NORM:** Bypass doors will automatically open and close based on the relevant systems logic. Bypass doors will normally stay in the closed position but will open automatically in the case of clogging over 100% or in the case of OEI.



## Failures & Damage Model

The H160 has a suite of failure modes and also a systems damage model for key aircraft systems. These features can be optionally disabled in the tablet Aircraft app, on the Setup page by setting **Aircraft Damage** to **Off**.

### Failure & Maintenance app

The Failures page shows a list of any active failures, and the maintenance page shows damage and degradation status.

Do All Maintenance: This will reset all damage

Aircraft failures are best triggered from within the mission system, as various timers or triggers may be devised to enter or exit the failure condition.



**Aircraft Failure Variables**

Scope	L:Vars
Engines	<p><b>0-100 (percent damage)</b>                      L:H160_PERSIST_DAMAGE_ENG1_PCT                      L:H160_PERSIST_DAMAGE_ENG2_PCT</p> <p><b>0 or 1 (boolean logic)</b>                      ENG ON FIRE:1                      ENG ON FIRE:2                      GENERAL ENG FAILED:1                      GENERAL ENG FAILED:2                      L:H160_FAIL_FADEC1                      L:H160_FAIL_FADEC2</p> <p><b>Note:</b> Using FADEC EMER will recover from level 3 to level 2 failure and thus regain substantial engine control by use of TOT-matching the engines.</p> <p><b>Bottles 0: empty, 1: charged</b>                      L:H160_SDK_FIREBOTTLE_1                      L:H160_SDK_FIREBOTTLE_2                      H:H160_SDK_FIREBOTTLE1_EMPTY                      H:H160_SDK_FIREBOTTLE1_FULL                      H:H160_SDK_FIREBOTTLE2_EMPTY                      H:H160_SDK_FIREBOTTLE2_FULL</p>
Hydraulics	<p><b>0 or 1 (boolean logic)</b>                      L:H160_FAIL_HYD1_LOWPRESS                      L:H160_FAIL_HYD2_LOWPRESS</p>
AFCS	<p><b>0 or 1 (boolean logic)</b>                      L:H160_FAIL_AP1                      L:H160_FAIL_AP2                      L:H160_FAIL_BKUP                      L:H160_FAIL_APCP</p> <p>L:H160_FAIL_PITCH_SEMA1                      L:H160_FAIL_PITCH_SEMA2                      L:H160_FAIL_ROLL_SEMA1                      L:H160_FAIL_ROLL_SEMA2                      L:H160_FAIL_YAW_SEMA1                      L:H160_FAIL_YAW_SEMA2                      L:H160_FAIL_COLLECTIVE_SEMA1</p>
Fuel	<p><b>0 or 1 (boolean logic)</b>                      L:H160_FAIL_FUEL_F                      L:H160_FAIL_FUEL_A</p>
Transmission	<p><b>0-100 (percent damage)</b>                      L:H160_PERSIST_DAMAGE_MGB_PCT                      L:H160_PERSIST_DAMAGE_TGB_PCT</p> <p><b>0 or 1 (boolean logic)</b>                      L:H160_FAIL_MGB_CHIP</p>
IBF System	<p><b>0-165 (percent clogging)</b>                      L:H160_PERSIST_IBF1_PCT                      L:H160_PERSIST_IBF2_PCT</p>
Other	<p><b>0 or 1 (boolean logic)</b>                      L:H160_SDK_MASTMOMENT_EXCEEDED                      H:H160_SDK_MASTMOMENT_EXCEED_ON                      H:H160_SDK_MASTMOMENT_EXCEED_OFF</p>

## Flight Management System

The H160 provides two different flight management systems:

- PMS50 GTN750 or TDSim GTNXi
- CMA9000

### GTN750 Flight Management System

The GTN750 acts as a flight management system, letting you manage the flight plan, locate nearby airports, view maps, and more. While both software integration options (by pms50 and TDSSim) are optional (the aircraft is usable without either option), it is highly recommended to select one or the CMA9000.

Available from either pms50 or TDSSim. Use the tablet Aircraft app (Options page) to select your preferred FMS.

pms50	TDSSim
<a href="https://pms50.com/msfs/">https://pms50.com/msfs/</a>	<a href="https://tdssim.com/tdsgtnxi">https://tdssim.com/tdsgtnxi</a>

The TDSSim GTN750 is integrated as 2 units, with unit 1 on the copilot side. You should manually set the navigation source to unit 2 to select the pilot unit. The invisible click spot is not implemented in the VR to switch navigation sources.

The TDSSim GTN750 does not currently save the flight plan into MSFS, so the NAVD and DMAP displays will not show the navigation route.

The pilot GTN750/CMA9000 is powered by both the avionics 2 bus and the essential 2 bus. This means that as long as the battery master is on, the GTN750/CMA9000 on the right side will have power. The copilot GTN750 is powered by only the avionics 1 bus. You will need to use the FMS 1/2 switch on the left overhead panel to gain access to the GTN750. Note also that COM2 and NAV2 are on the pilot (right) side of the aircraft, and COM1/NAV1 on the left side.

### GTN750 Software Options

Mode	Installation Procedure
Pms50 GTN750 <b>(Recommended)</b>	Install the <a href="#">pms50 GTN750</a> . You will have two folders within Community: hpg-airbus-h160 pms50-instrument-gtn750
TDSSim GTNXi	Purchase and install the <a href="#">TDSSim GTNXi</a> .  On the H160 tablet, go to the Aircraft app, Options page, and select <b>GTN Software to TDSSim GTNXi</b> .  You will have two folders within Community: hpg-airbus-h160 tds-gtnxi-gauge
No GTN750 <b>(Not Recommended)</b>	The GTN750 provides important flight management functions which would not otherwise be available, however a flight plan may still be selected and used from the world map.  You will have only one folder within Community: hpg-airbus-h160

#### Pms50 GTN750

The free version is suitable but the premium version adds many features including navigraph charts, checklists and more. The addon is not included in the H160 download, check the installation instructions earlier in this guide for specific installation steps.

A **Not Installed** message indicates that the GTN750 addon was not discovered. Check your Community folder for the pms50-instrument-gtn750 folder



#### Checklists

To install the checklist follow this procedure: **(Premium GTN750 required)**

1. Unpack the checklist zip file. Rename HPG\_AirbusH160\_The1L2P.json to import.json and place the file into Community\pms50-instrument-gtn750\checklists\gtn750. Overwrite the existing import.json file.
2. Inside MSFS: In the GTN750 click on: System -> Setup -> Checklists -> Import local file
3. You'll find the checklist under Utilities -> Checklists.

#### Registration

The GTN750 registration page is for the premium GTN750 license. **Do not enter your H160 license key into GTN750.**

#### Disable an individual FMS unit

Push buttons may be used to blank the FMS screen and disable processing for that MSFS gauge.



## Operating the GTN750

### Direct-To airport procedure

If you have an existing flight plan, a Direct-To will replace it with a new flight plan that goes from your current position to the destination. Start from the GTN750 Home page. If you don't see the home page, select the HOME button and you will see a grid of icons. The destination may be found by selecting a nearby airport from a list or by selecting the 4-digit ICAO airport code.

After activating a Direct-To flight plan, you can use the tablet autopilot panel to select the GPS navigation source, or you can use the NAV and CPL softkeys on the pilot MFD to select and couple the navigation source.



### Direct-To: Select a nearby airport

<p>1. Select Nearest</p>	<p>2. Select Airport</p>	<p>3. Select an airport</p>
<p>4. Select the Direct-To button</p>	<p>5. Select Activate</p>	

### Direct-To: Select an airport by name

1. Select <b>Waypoint Info</b>	2. Select <b>Airport</b>	3. Select ---
--------------------------------	--------------------------	---------------



4. Type an ICAO (e.g. KSEA)
5. Press ENTER



6. Select the Direct-To button



7. Select Activate



NOTE: WTT Mode is inoperative with version 2.0!

Enter transponder code and turn ON and OFF

1. Select Transponder (in full version on Copilot side)

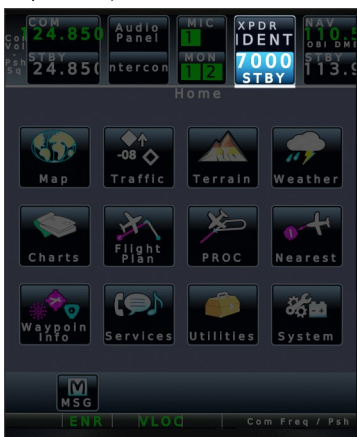

2. Enter Code or press VFR



3. Press ON

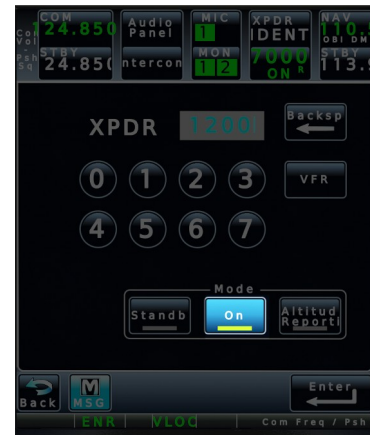

4. Press ENTER

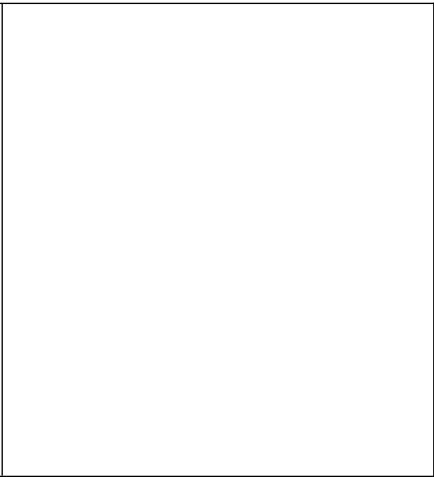
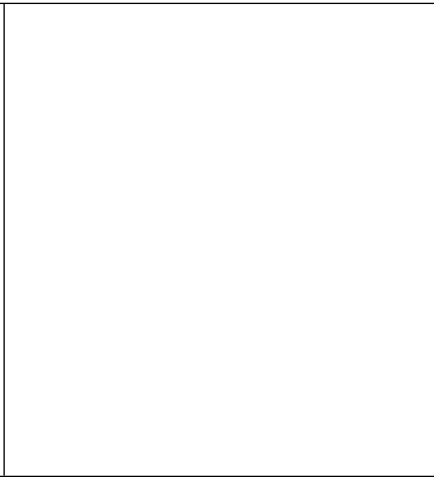

## CMA9000 FMS Supplement

The HPG CMA9000 FMS features capable flight management for rotorcraft.



### System Overview

#### Display Function Buttons

The FMS has 6 Line-Select keys on the left and right side of the screen. These correspond to the functions labeled next to the key.



Text entered on the FMS is entered into the scratchpad, which is the line at the bottom of the screen. This text can be modified by typing and then entered into a field by selecting the adjacent Line Select Key.

#### Keypad Function Buttons

- MENU:** Access the MCDU MENU page.
- PREV/NEXT:** Previous Page and Next Page buttons cycle through the active pages.
- INIT+REF:** Access to INITIALIZE and REFERENCE LIBRARY..
- RTE:** Access the ROUTE page.
- DEP+ARR:** Access to the DEPARTURES and ARRIVALS procedure selection pages.
- LEGS:** Access to the route LEGS page or waypoints page.
- EXEC:** EXECUTE or save the current changes
- RADIO:** Access the RADIO page.
- FUEL:** Access the FUEL page.
- MARK:** MARK ON TOP function and opens PREDEF WPF page.
- HOLD:** Access the HOLD page
- FIX:** Access the FIX INO page.
- BRT:** Adjust screen brightness.



**Execute Function**

Modifications to the active flight plan will require EXEC to be pressed, the corresponding green light will be illuminated when there are unsaved changes to the active flight plan.



**Flight Plan Functions**

**Entering origin and destination airports**

1. Open the ROUTE page by pressing the **RTE** button.
2. Key the origin airport into the scratchpad such as **LOWI**. Select **LSK1** (Origin) to insert it.
3. Key the destination airport into the scratchpad such as **EDDM**. Select **RSK1** (DEST) to insert it.
4. Select **EXEC** to save the changes.
5. Open the MFD **NAVD** or **DMAP** page and observe a direct route between LOWI and EDDM.

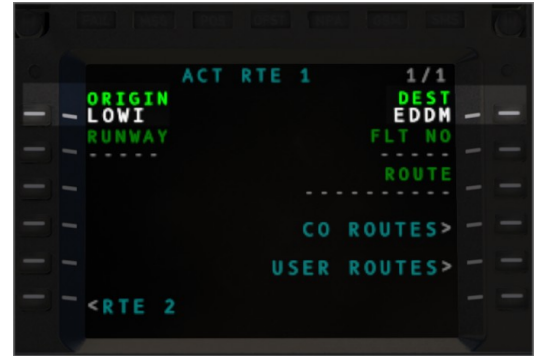

**Add En-route legs**

1. Open the LEGS page by pressing the **LEGS** button.
2. Enter a waypoint such as **RUM** in the scratchpad. You may get a selection page to choose which waypoint you like. Press **NEXT** or **PREV** Button to find the correct one.
3. Press **LSK1** to sequence the new waypoint ahead of **EDDM**. Waypoints are sequenced prior to the selected waypoint entry location.
4. Press **EXEC** to save the changes, and observe the new route on **NAVD** or **DMAP**.

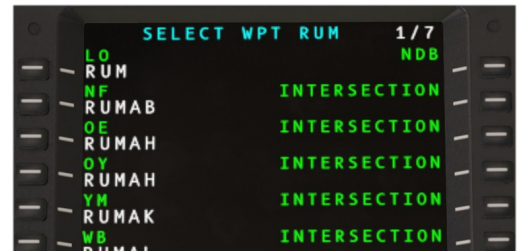

NOTE: Use the **CLR** key to enter DELETE into the scratchpad, which can be used to remove a single waypoint. Additionally you may "move up" a waypoint to remove one or more waypoints.

### Selecting Departure procedures

1. Open the DEPARTURES/ARRIVALS INDEX by pressing the **DEP/ARR** button.
2. Select **DEP** under RTE 1
3. On the departures page, select a runway such as **08** and a departure procedure such as **RTT2Q**. Select a departure transition if applicable.
4. Press **EXEC** to save the changes, and observe the new route on **NAVD**.

NOTE: You may also enter the runway on the ROUTE page.

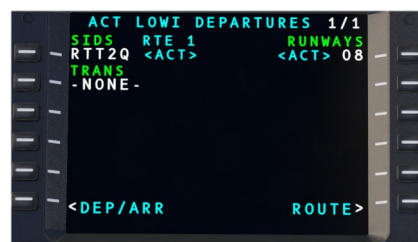

### Selecting Arrival and Approach procedures

5. Open the DEPARTURES/ARRIVALS INDEX by pressing the **DEP/ARR** button.
6. Select **ARR** under RTE 1
7. On the arrivals page, select an approach such as RNAV RW34L and an arrival procedure and transition if applicable.
8. Press **EXEC** to save the changes, and observe the new route on **NAVD**.

Autopilot navigation following the flight plan

1. On **NAVD**, press the **NAV** button to cycle through sources. Select the **FMS** source
2. Press the **CPL** key at the bottom of the screen to begin navigation

NOTE: The source must remain visible for the AFCS to continue following that navigation source.

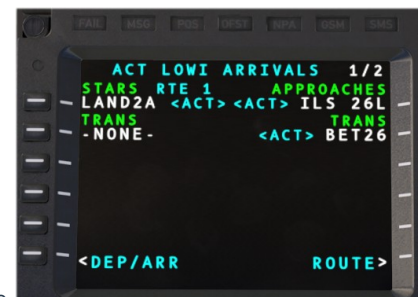

### Deleting the flight plan

If the flight plan is activated:

You can only delete a flight plan that has already been activated if you are on the ground. If you need to make a change in the air (e.g. new destination airport), you can do this using the RTE2 function. (see Alternative route (RTE2)).

If you are on the ground, you can simply overwrite the entries for **ORIG** and **DEST** with a new entry (e.g. EDDF). On the **DEP/ARR** page you will then find the corresponding approach and departure procedures for the newly entered start or destination point.

If the flight plan is not yet activated:

1. press **RTE**
2. press **LSK4** (ERASE RTE)
3. press **EXEC**

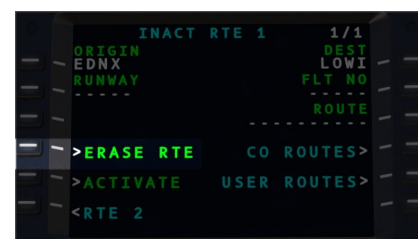
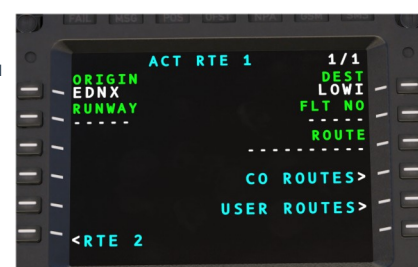

### Direct-To

#### Direct-to a waypoint in the active route:

1. Display **LEGS** page by pressing **LEGS**
2. Display the desired waypoint by pressing **NEXT** or **PREV** as required
3. Key in, or copy the waypoint identifier into the scratchpad by pressing the appropriate **LSK**
4. Return to the first **LEGS** page by pressing **LEGS** or **PREV** as required
5. Move the waypoint identifier to the **TO WPT** field by pressing **LSK1**
6. Verify the inbound course and distance of the leg to the **TO WPT** and press **EXEC**

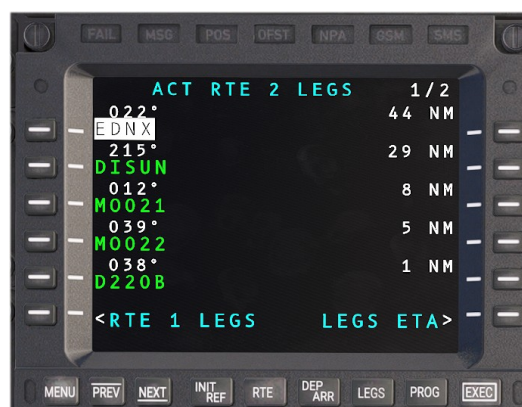

#### Direct-to an off-route waypoint

1. Key in the off-route waypoint identifier
2. Display the first **LEGS** page by pressing **LEGS**
3. Move the waypoint identifier to the **TO WPT** field by pressing **LSK1**
4. Verify the inbound course and distance of the leg to the **TO WPT** and press **EXEC**



### RTE 2 Option

The CMA 9000 offers you the option of creating two independent routes simultaneously (RTE 1 and RTE 2), whereby only one of the two routes can be activated as an active flight plan. The other flight plan is saved as an inactive route.

The inactive route can either be created manually or selected from the custom routes. It can also be copied from the active route. The procedures for creating, selecting or editing the inactive route are identical to those described for the active route.

*Note: The inactive route is always displayed in monochrome cyan so that it can be clearly distinguished from the active route.*

#### Edit an inactive route:

1. display the active route by pressing RTE
2. go to the menu navigation of the inactive route by pressing LSK6 (RTE2)
3. the inactive route can now be manipulated directly via the RTE, LEGS, DEP/ARR and HOLD pages, as already described for the active route

*Note: Any changes to the inactive route are either confirmed via the respective LSK with "CONFIRM" or deleted with "CANCEL". You cannot execute an EXEC command here.*

#### Activate an inactive route:

1. go to the routes menu by pressing RTE
2. if you are not yet in the area of the inactive route, press LSK6 (RTE 2 or RTE 1, depending on which route is active)
3. you are now in the area of the inactive route (monochrome cyan). To activate the inactive route, press RSK6 "ACTIVATE".

#### Copying an active route:

1. to copy an active route to an inactive route, press LSK5 ("RTE COPY") on the side of the inactive route (cyan). The active route remains untouched and will continue to be used for navigation.
2. press RSK6 ("CONFIRM") to copy the route

*Note: A copied route always contains the last status of the active route including the current TO waypoint and all subsequent waypoints. Waypoints that have already been overflown are not copied.*

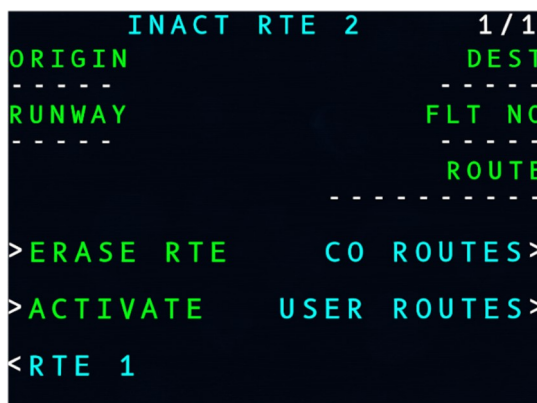

## Aircraft Functions

### Find nearby airports and Nav aids

1. Select INIT/REF, then NEAREST, then AIRPORT or VHF/NAV
2. Wait for the data to load
3. A list is presented of the nearest 50 airports or nav aids



### Tune COM1 or COM2 radio

1. Open the RADIO page by pressing the RADIO button.
2. Key in a new frequency in the scratchpad, such as 121.70
3. Select RSK1 or RSK2 for COM1 or COM2
4. The frequency will be entered into the standby slot, press the same SK a second time to swap it to the active frequency.



### Tune NAV1 or NAV2 radio

5. Open the RADIO page by pressing the RADIO button.
6. Key in a new frequency in the scratchpad, such as 116.80
7. Select RSK3 or RSK4 for NAV1 or NAV2
8. The frequency will be entered into the standby slot, press the same SK a second time to swap it to the active frequency.

### Enter transponder code

1. On the RADIO page, enter the new 4-digit transponder code
2. Press LSK4 to enter the code into the standby slot
3. Press LSK4 again to swap the active and standby slots

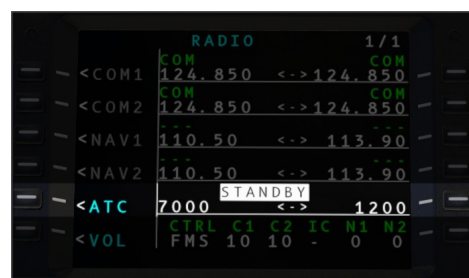

**Turn transponder ON and OFF**

4. On the **RADIO** page, Select the **ATC** menu at RSK5.
5. Press LSK3 to cycle between transponder states. Press LSK2 to toggle MODE C reporting.



**Advanced Functions**

**Mark on top (create waypoint)**

1. Press the MARK button as you overfly a location
2. The PREDEF WPT page will open with the MARK position indicated
3. Press RSK1 to copy the position to the scratchpad
4. Create a new user waypoint by clicking NEW USER WPT



5. Enter the position into RSK2
6. Enter an identifier into LSK1
7. SAVE to save the waypoint to the user database



NOTE: View the PREDEF WPT page without marking a new position, by using INIT/REF → WPT LISTS -> PREDEF WPT to access the page.  
 NOTE: The JOYSTICK position is the DMAP cursor and may also be used to easily create new user waypoints.

**Enter PlaceBearing/Distance waypoint**

You may create a new fix based on an existing fix and a bearing/radial and distance.

A fix may be entered with a bearing and distance such as:  
 KSEA000/10 Fix: KSEA with Bearing: 000 and Distance 10 NM  
 KSEA180/10/R Fix: KSEA with Radial: 180 and Distance 10 NM

After creation the waypoint will be visible with an incrementing identifier, such as KSEA01

**Enter or modify a holding pattern**

Enter /H into the scratchpad on the LEGS page, then select a waypoint. This will promote the waypoint to a hold and display the HOLD page. On this page you may select the hold details such as Right or Left turns, leg time and the inbound course. Use EXEC to save the changes. Enter / into the scratchpad to clear the hold procedure from a given waypoint.

**Enter or modify a search pattern (SAR)**

1. Enter /S into the scratchpad on the LEGS page, then select a waypoint. This will promote the waypoint to a search pattern and display the SEARCH PATTERN page
2. Enter the pattern details such as the type, leg length and track spacing. Select between Square, Ladder or Sector patterns
3. Press ACTIVATE to save into the modified flight plan. You may check the results on NAVD.
4. Press EXEC to commit the changes to the active flight plan.

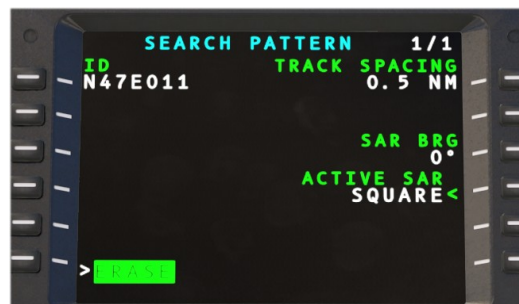

Enter / into the scratchpad to clear the SAR procedure from a given waypoint.



**Editing the Company Database**

The Company Database may be edited at the following location:

Community\hpg-airbus-h160\html\_ui\HPGH160-System\CMA9000\COMPANY\_DATABASE.json

Company database contains:

- Routes with origin, destination and en-route waypoints as they would be entered on the LEGS page.
- Custom waypoints
- Information for the IDENT page

**Editing the User Database**

The user database is created automatically but may be edited by the user if needed.

The location for Windows Store is:

%LocalAppData%Packages\Microsoft.FlightSimulator\_8wekyb3d8bbwe\LocalState\packages\hpg-airbus-h160\work

The structure and information contained is identical to the Company Database.

**Select flight plan from company route list**

1. From the ROUTE page, select **CO ROUTES**
2. Select from the list of routes
3. The route will be applied immediately, **!WAIT** will be displayed multiple times while looking up data. You may be asked to disambiguate waypoints.
4. Press **EXEC** to commit the changes to the active flight plan.

NOTE: Company database must be installed.



## Hype Tablet

The tablet may be opened or closed by clicking the hinge. The home button will close apps until there are no more apps open, then will also close the tablet. If you use the hinge you may keep the app open while the tablet is closed. The tablet battery will drain if you do not turn on the helicopter and also engage the DC RECEIPT switch.

**Tablet Hinge:** Click the hinge along the left to open or close the tablet.

**Home Button:** The home button will close the current app (or view) until showing the home screen, and then one more press will close the tablet.

**Status bar:** Action Center is available by clicking the status bar at the top of the screen



## Apps

Aircraft	Configure the aircraft here
Failures & Maintenance	Configure aircraft failures and restore aircraft damage here.
Missions	Discover and execute missions here.
Documents	View image charts of your choosing. A copy of the user guide and normal procedures is also included here.
LittleNavMap	View the LittleNavMap.exe view from the tablet.
Sound Mixer	Adjust aircraft sound intensities here.
Maps	View maps.
Alarms	Set alarms and timers.
METAR	Query METARs for airports (live weather).
Web	Access select (very restricted) web pages directly.
EFBConnect	Mirror web pages into the simulator.
Flappy Bird	A simple game (to be used only on the ground).
Neopad	Access the NeoFly app
Direction Finder	Configure the DF hardware with a location.
Event Tester	Test the Home Cockpit SDK events without first binding the controls.

## Aircraft (Setup)

The aircraft app combines unrealistic functionality with required setup and equipment and options configuration.



## Setup

Setting	Options	Notes
Gameplay Mode (Flight Model)	Realistic Arcade	<b>Realistic mode</b> is the default flight model and is much more advanced. Arcade mode is an older version which some users may prefer but is not recommended.  <b>Arcade mode</b> will also disable advanced flight model features: <ul style="list-style-type: none"> <li>- Rotor overspeed and underspeed</li> <li>- Vortex Ring State</li> <li>- Aircraft Damage</li> </ul>
Vortex Ring State	Off / On	VRS is a dangerous condition where the aircraft descends into its own downwash.  Not available in Arcade mode.
Aircraft Damage	Off / On	Damage to Transmission and Engines, IBF simulation that will restrict engine airflow and

		subsequent power available Not available in Arcade mode.
AFCS ATT Follow-Up Trim	Off Only Cruise Only Hover Both	When in ATT mode (blank on the MFD), this setting controls whether trim release is required at lower or higher speeds.
Cyclic Sensitivity	(-10)-(+10)	This setting is intended to compensate for a cyclic control which is longer or shorter (like an xbox controller or a more professional control setup)
Hands On detection	None Deadzone Motion Rate Ignore	
Cyclic Deadzone	1%-100%	This configures the deadzone used by the AP to determine when you are pushing on your joystick controller vs leaving it neutral/at rest.  Select the lowest value that still results in your controller being consistently detected correctly (yellow=you are pushing on it, white=at rest)
Pedals Sensitivity	(-10)-(+10)	
FEET On detection	None Deadzone Motion Rate	
Pedals Deadzone	1%-100%	Same as above, but for pedals

State Load	Options	Notes
Ready for Takeoff	Configures the aircraft for takeoff (engines, AFCS).	
Cold & Dark	Configures the aircraft for Cold & Dark at the ramp.	

## Equipment

Setting	Options	Notes
Radome (Weather Radar)	Installed Not Installed	This option will be set by the livery author and may then be changed at any time.
Emergency Floats	Installed Not Installed	
Hover Pump	Installed Not Installed	
Belly Tank	Installed Not Installed	

## Options

Setting	Options	Notes
FMS System Software	Pms50 GTN750 TDSSim GTNXi CMA-9000	See the GTN750 or CMA-9000 section of the <a href="#">user guide</a> for more information. Restarting the flight is not necessary but it is not recommended to load both GTN750 software options concurrently.
Fuel Units	Lb (Pounds) Kg (Kilograms) L (Liters) Gal (Gallons)	
Weight Units	Kg (Kilograms) Lb (Pounds)	
Barometric Units	In/Hg hPa	Controls the baro readout on the 3 MFDs and IESI.
Temperature Units	C F	Displays the OAT (outside air temperature) value on the FND page in either fahrenheit or celsius
Rotor Downwash Effects	On Off	Particle effects on dirt/grass, sand, snow, water. Has GPU impact
Pilot automatic hide	Head & Body Head Only	This setting controls whether you can slew into the pilot bodies in the cockpit Use the Head Only setting if you experience the pilot flickering based on your movements with TrackIR or VR

### Crew & Payload

Setting	Options	Notes
Seat Selection - Pilot Seat Selection - Coilot	Hype Asobo	Choose to use Hype pilot models or Asobo. <b>Note</b> only the Hype pilots may operate as headless
Seat Selection - 2	Crew Worker	Choose which human model type to use
Seat Selection - 3 Seat Selection - 4-12	Worker Survivor	Choose which human model type to use Note: H160 can transport up to 12 person. Standard 12, Luxury 4.
Hoist Selection	Stowed Deployed Crew Crew+Stretcher Worker Crew+Survivor 1 Crew+Survivor 2 Containers Hose	Stowed (Hoist is stowed and off) Deployed (Hoist arm swings out)  Choose the hoist objects currently attached. <b>Note</b> unless using a mission, the object will not automatically detach when reaching the ground <b>Note</b> options available vary per variant
Fueling	25% 50% Full	

### Maps app

The maps app features zoom controls and the ability to change the map orientation between North-Up and Heading-Up modes. The current magnetic heading is also displayed in a digital/numeric value at the top of the page.

Click [...] to reveal the maps selection panel where you may select between a variety of map sources as well as airspace and weather overlays.

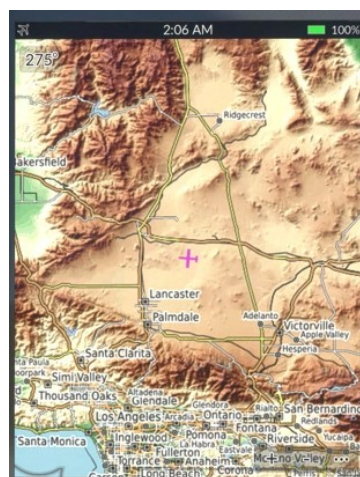

#### Advanced Configuration (Optional)

The maps app uses OpenStreetMap tile data. You may configure the sources and their relevant options through the configuration file located at:

html\_ui\HPGH160-User\Tablet\MapsApp.json.

Edit this file to change from the default provider of

https://{a-c}.tile.opentopomap.org/{z}/{x}/{y}.png.

See here for more providers: <http://leaflet-extras.github.io/leaflet-providers/preview/>

### Documents app

The Documents app is a simple image chart viewer app. It will show documents built into the H160, provided by your livery, or documents of your own choosing.

To show your own "user documents":

1. Install the [UserDocuments](#) package in your Community folder. You will install this new folder alongside the main hpg-airbus-h160 folder, don't put it inside of the main H160 folder.

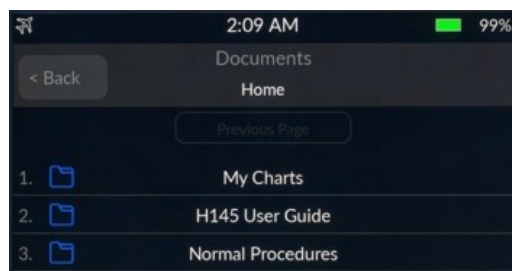

2. Place your files in  
hpg-airbus-h160-userdocs\html\_ui\HPGH160-User\Documents

3. Double click the script **Update Docs For Sim** in the UserDocuments. This will overwrite the Index.json which the sim reads the filenames from. It will also update the package layout.json. You must restart your sim after adding or removing files.

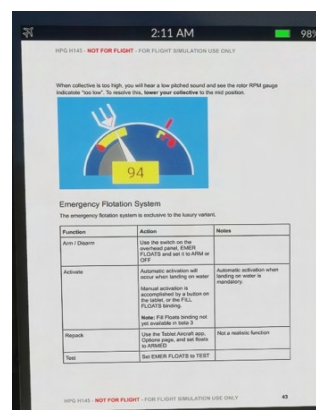

## Neopad app

### [Download Neofly and Neopad](#)

The neopad app is present ONLY if neopad is installed within the simulator. You should see Neopad on the sim toolbar. Once installed, the app will be visible on the tablet. The app will simply connect to the NeoFly app, so make sure the toolbar app is working as expected if you are having any problems.

The neopad server url may be changed via: `Community\hpg-airbus-h160\html_ui\HPGH160-User\Tablet\NeopadApp.json`.

## Web Browser

The browser app will load websites which have an access-allow-origin set to allow the game to access it, which is unfortunately rare. Web Browser app will load URLs from `Community\hpg-airbus-h160\html_ui\HPGH160-User\Tablet\WebBrowserApp.json`.

## EFB Connect (Web Browser)

EFBConnect is a companion app which runs on your PC and provides a web browser with more functionality inside the sim, including some ability to stream video.

Download EFBConnect from here:  
EFBConnect is here:

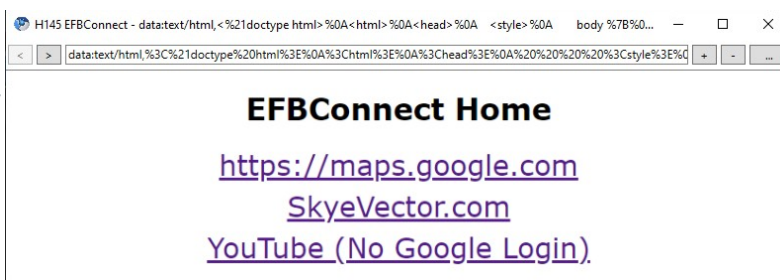

<https://drive.google.com/file/d/1dRUgqLARGRTypUOYag7junVOX49b15G/view?usp=sharing>

It includes a quick start guide explaining the basic functionality (it is currently outdated and refers to H135).

EFBConnect will load to the configurable home page:

As soon as EFBConnect opens, the tablet EFBConnect app will automatically connect. You are able to send mouse clicks directly on the tablet in the sim, but currently you cannot scroll or zoom or use the back button.

Content that you view in the EFBConnect app will be mirrored in the sim, and light tasks may be accomplished directly through the sim.



## LittleNavMap app

### [Download LittleNavMap](#)

The LittleNavMap app contacts the LittleNavMap webserver. Click Tools then **Run Webserver** to start it. You can test that it is working by viewing the page in your browser.

### Advanced Configuration

There is no need to change the below but the options are available if needed, especially changing the Url to another computer.

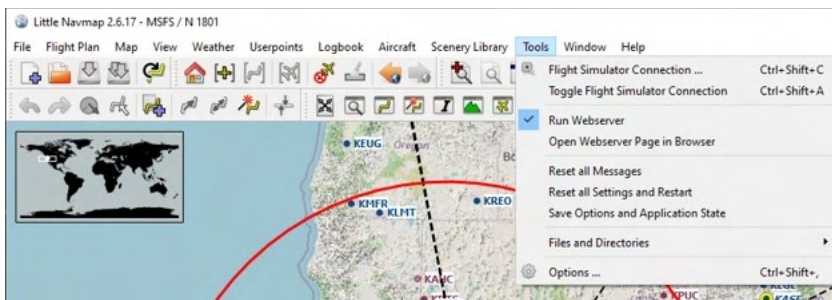

Configuration file: `html_ui\HPGH160-User\Tablet\LittleNavMapApp.json`.

Parameter	Values	Notes
Url	Default: <code>http://localhost:8965</code>	Server location (ip or host name including protocol)
FrameDelay	Default: 1000	Milliseconds to wait after receiving a frame before loading the next frame
Scale	Default: 1	Requested view size
ZoomScale	Default: 2	Zoom increment
Format	jpg or png (Default: jpg)	
Quality	0-100 (Default: 80)	JPEG compression level

Parameters are passed directly to the LittleNavMap web server.

## Events Tester

The Events Tester app is intended as a simple way to check key bindings prior to selecting them in ConfigTool. Events Tester presents a list of categories and within each category are commands which correspond to functions in the H160. The command will execute each time you tap on the entry.

## Sound Mixer

The Sound Mixer app presents sliders to adjust certain aircraft sounds.

Name	Notes
Rotor Bladeslap	Heavier rotor blade sounds when the air collides with recently disturbed air. Lower values are recommended
Avionics Alerts - Critical	
Avionics Alerts - Advisory	
Crew Audio	Crew guidance audio. <b>Not yet operative.</b>

## Direction Finder

The Direction Finder (DF) app presents an interface to set entries from DFApp json as the active DF source. The DF bearing pointer is available on FND and NAVD under the BRG1 and BRG soft keys.

The file location for entries is `hpg-airbus-h160\html_ui\HPGH160-User\DFApp\index.json`.

## Hype Radio

Listen to internet radio stations based on your flight simulator location. Start the Hype Operations Center app on your PC and then click Hype Radio on the tablet.

Radio stations will be updated every time you launch the app and the radio will remain playing even if you leave the range of the station, or go to the menu to change location.



## Wallpaper

The tablet wallpaper is located at `html_ui\HPGH160-User\Tablet\wallpaper.jpg`

The wallpaper may also be set based on the currently active livery. See the **Livery Author Info** section for more info. For your own persistent wallpaper you can use `\hpg-airbus-h160-userdocs\html_ui\HPGH160-User\Tablet\wallpaper.jpg`

## Action center

The Action Center is available from all apps and opens on top of any currently opened app. Click the clock to activate the Action Center.

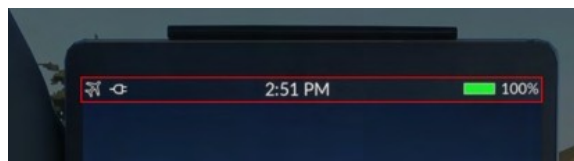

## Always-visible sections

These sections are available at the top of the Action Center under all conditions.

Tablet Brightness control	
Doors	
Autopilot	

<p>Autopilot - extended controls</p>	
<p>Lights</p>	
<p>Lights - with extended HISL controls</p>	

**Contextual sections**

These sections (or notifications) are available only when certain conditions are met



<p>TDSSim GTNXi Navigation Source</p>	
<p>One Engine Inoperative</p>	
<p>ELT Active</p>	
<p>Hoist Control</p>	
<p>Emergency Flotation System</p>	

Ground Power Available	<div style="background-color: #333; color: white; padding: 5px;"> <p>Ground Power Available External power is available for the aircraft.</p> <p style="text-align: right;"><a href="#" style="background-color: white; color: #333; border-radius: 10px; padding: 2px 10px;">Connect</a></p> </div>
Open Door	<div style="background-color: #1a2b3c; color: white; padding: 5px;"> <p>Open Door One or more doors are open.</p> <p style="text-align: right;"><a href="#" style="background-color: white; color: #1a2b3c; border-radius: 10px; padding: 2px 10px;">Close All</a></p> </div>
Bambi Bucket	<div style="background-color: #1a2b3c; color: white; padding: 5px;"> <p>Bambi Bucket Bambi Bucket is attached to the helicopter.</p> <p style="text-align: right;"><a href="#" style="background-color: white; color: #1a2b3c; border-radius: 10px; padding: 2px 10px;">Dump Bucket</a></p> </div>
Parking Brake Applied	<div style="background-color: #1a2b3c; color: white; padding: 5px;"> <p>Parking Brake Applied Sim parking brake is engaged (no effect).</p> <p style="text-align: right;"><a href="#" style="background-color: white; color: #1a2b3c; border-radius: 10px; padding: 2px 10px;">Release Brakes</a></p> </div>
Rotor Braking Available	<div style="background-color: #1a2b3c; color: white; padding: 5px;"> <p>Rotor Braking Available Rotor brake operation is allowed.</p> <p style="text-align: right;"><a href="#" style="background-color: white; color: #1a2b3c; border-radius: 10px; padding: 2px 10px;">Apply rotor brake</a></p> </div>





### Status bar

Icons in the status bar are always contextual based on equipment and conditions. Icons will appear and disappear based on events like the GPU being made available, and icons will use a background color to draw additional attention to specific statuses.

#### GPU status icons



	GPU is connected and on. You must disconnect prior to takeoff.
	GPU is available but not currently connected.

#### Cargo Hook (with Remote Hook) status icons





	Remote Hook is attached, no load, off the ground.
	Remote Hook is attached, no load, within range of attach/detach
	Remote Hook is attached, with load, off the ground
	Remote Hook is attached, with load, within range of attach/detach

#### Bambi bucket status icons

	Bambi bucket is attached, empty, and off the ground.
---	--

	Bambi bucket is attached, and below the ground level
	Bambi bucket is attached, has water, and above the ground level.
	Bambi bucket is attached and currently dumping

**Other status icons**

	One or more doors are currently open.
	Rotor braking is available
	ELT is actively broadcasting.
	Parking brake is on and the setting is also on to show it (normally hidden)

## AFCS (Autoflight System)

The H160 autopilot is a comprehensive autoflight system, capable of both basic stabilization and also fully-hands-off upper modes. The system combines redundant Stability Augmentation Systems with redundant aircraft management computers, which take data from aircraft sensors and send command to the actuators. The systems are monitored by and interacted with through the MFDs, Autopilot control panel (APCP) and controls on the cyclic and collective.

### Background

The H160 flight controls are augmented by parallel actuators, called SEMAs (smart electro-mechanical actuator). These parallel actuators are invisible to the pilot (not felt in the controls) and are controlled by aircraft computers directly. The SEMA are quick and powerful but limited in travel. The total SEMA travel will be only 10% of the pitch axis and 20% of the roll and yaw axis. For this reason, the AFCS also needs the ability to re-center the SEMA. The A.TRIM (auto trim) system is able to receive commands from the AFCS computers and then slowly drive the trim motor in the requested direction. As the trims move, the pilot sees and feels their cyclic moving. It is for this reason that the A.TRIM system must be engaged to use UPPER MODES, as otherwise the saturation of the SEMA could not be automatically resolved by the computers.

Community member Josh has created a detailed [H145 Autopilot explanation video](#) .

### Trim Release

Trim Release (Cyclic Trim Release) is a button on the cyclic control which the pilot holds anytime they are manipulating the cyclic. This is a very important aspect of H160 and doing so both pauses the AFCS (so it doesn't fight you) and also gives you maximum precision. There is also a [Collective Trim Release](#) , but it isn't as necessary as the cyclic version.

Holding Trim Release is known as **Fly-Through Action**.

### Follow-Up Trim

Follow-Up trim will allow you to manipulate the cyclic without using trim release, however this will only work well if you also have a very small H160 cyclic deadzone setting. Even still, Trim Release is recommended for all users. Note that Follow-Up trim is only enabled on ATT mode (and submodes). When follow-up trim is active, attitude setpoints will be updated for any deflection. Follow-Up trim has 4 settings. The **Only Hover** option is considered the realistic setting, but **Off** is recommended for learning and understanding the systems.

Setting	Mode
Off	Follow-up trim is never active.
Only Hover	When below 30kias, follow-up trim is active.
Only Cruise	When above 30kias, follow-up trim is active.
Both	Follow-up trim is always active.

### AFCS OFF and A.TRIM OFF Operation

Pilots are to fly with AFCS engaged during all normal operations. A.TRIM OFF is advised for sloped landings or with a heaving deck. Turning A.TRIM off ensures that the attitude change sensed does not result in flight control input that could injure those working around the aircraft. AFCS and A.TRIM may be disengaged for training purposes at the pilots discretion.

### ATT / Attitude Hold

Attitude hold mode (ATT) is the default autopilot mode and available independently on all 3 axis. Attitude hold mode provides long term attitude stabilization. This mode is also sometimes known as **basic autopilot**. As it is the default mode, it is **not** visualized on the AFCS Status Strip.

Engagement: ATT is engaged automatically when at least one SAS is available and no other mode is selected. It is automatically engaged when disengaging any upper mode.

Reference Management: Use [Cyclic Trim Release](#) or [Cyclic Beep Trim](#) to change pitch and roll attitude.

Fly-Through Action: Hold new attitude.

\* - ATT mode turn coordination is inoperative.

### DSAS / Digital SAS

DSAS mode is actually a degraded sub-mode of ATT. It is engaged automatically on any axis when the A.TRIM function is inoperative. The mode provides short term attitude stabilization, however long term stabilization is not assured due to lack of auto trim.

Engagement: [A.TRIM](#) Toggle or automatically due to trim failure.

Reference Management:

Use [Cyclic Trim Release](#) or [Cyclic Beep Trim](#) to change pitch and roll attitude.

Use [Collective Beep Trim Left/Right](#) to trim the yaw pedals. Fly-Through Action: Hold new attitude.

### HDG and TRK / Heading Hold

Heading hold mode will use yaw in low speed (less than 30kt) and roll and yaw at higher speeds. Track mode will use a GPS ground track. Use the APCP butterfly knob to change to TRK.

Engagement: [HDG](#) Toggle on the APCP.

Reference Management: [Cyclic Beep Trim Left/Right](#) will change heading reference.

Fly-Through Action: Return to selected heading.

## VS and FPA / Vertical Speed

VS mode will acquire and maintain a vertical speed. FPA (flight path angle) will use a GPS ground reference. Use the APCP butterfly knob to change to FPA.

Engagement: **VS** Toggle on the APCP.

Reference Management: **Collective Beep Trim Up/Down** will change heading reference.

Fly-Through Action: Return to selected VS.

## ALT / Altitude Hold

ALT mode will maintain the altitude at engagement.

Engagement: **ALT** Toggle on the APCP.

Reference Management: **Collective Beep Trim Up/Down** will change altitude reference.

Fly-Through Action: Return to selected altitude.

## ALT.A / Altitude Acquire

ALT.A mode will use VS mode to acquire and maintain an altitude. Change the ALT.A reference on the APCP, then engage the ALT.A by pushing the knob.

Engagement: **ALT.A** Toggle on the APCP.

Reference Management: **Collective Beep Trim Up/Down** will change altitude reference.

Fly-Through Action: Return to selected altitude.

## IAS / Indicated Airspeed Hold

IAS mode will acquire and maintain an selected airspeed.

Engagement: **IAS** Toggle on the APCP.

Reference Management: **Cyclic Beep Trim Up/Down** will change airspeed reference.

Fly-Through Action: Return to selected airspeed.

## GA / Go-Around

GA mode will act similarly to IAS and VS. It executes for 15 seconds in cruise and 25 seconds from a hover.

Engagement: **Collective GA** press.

Reference Management:

**Cyclic Beep Trim Up/Down** will change airspeed reference.

**Collective Beep Trim Up/Down** will change the VS reference. Fly-Through Action: Return to selected airspeed and VS.

## GTC / Ground Trajectory Command

GTC mode will maintain current ground-referenced speeds on longitudinal and lateral axis, as well as heading hold on the yaw axis.

Engagement: **GTC** press once.

Reference Management:

**Cyclic Beep Trim Up/Down** will change Vy reference.

**Cyclic Beep Trim Left/Right** will change Vx reference. Fly-Through Action: Update Vy and Vx references.

## GTC.H / Auto Hover

GTC.H is a sub-mode of GTC and will acquire and maintain a fixed ground-referenced position.

Engagement: **GTC** press twice.

Reference Management:

**Cyclic Beep Trim Up/Down** will change the longitudinal position by approximately 1 meter.

**Cyclic Beep Trim Left/Right** will change the lateral position by approximately 1 meter. Fly-Through Action: Update to new position.

## VOR / VOR Navigation

LOC mode will track a localizer in order to conduct an instrument landing.

Engagement: **CPL** key on FND, NAVD or DMAP page.

Reference Management: CRS key may be available (note: MSFS may still restrict changing LOC course), on NAVD or FND pages.

Fly-Through Action: Return to tracking LOC.

## LOC / Localizer

LOC mode will track a localizer in order to conduct an instrument landing.

Engagement: **CPL** key on FND, NAVD or DMAP page.

Reference Management: CRS key may be available (note: MSFS may still restrict changing LOC course), on NAVD or FND pages.

Fly-Through Action: Return to tracking LOC.

## NAV / FMS Navigation

NAV mode will track a FMS navigation source.

Engagement: **CPL** key on FND, NAVD or DMAP page.

Reference Management: None. Use FMS to change flight plan.

Fly-Through Action: Return to tracking FMS.

## GS / Localizer Glideslope

GS mode will track a localizer glideslope in order to conduct an instrument landing.

Engagement: **CPL** key on FND, NAVD or DMAP page.

Reference Management: None.

Fly-Through Action: Return to tracking GS.

## APP / Approach

APP mode will track an approach in order to conduct an GPS procedure landing.

Engagement: **CPL** key on FND, NAVD or DMAP page.

Reference Management: None.

Fly-Through Action: Return to tracking APP.

## V.APP / Vertical Approach

V.APP mode will track a glidepath in order to conduct an GPS procedure landing.

Engagement: **CPL** key on FND, NAVD or DMAP page.

Reference Management: None.

Fly-Through Action: Return to tracking G/P.

## Livery Author Info

This section is for those who make aircraft paints (liveries). Many liveries are available already at <https://flightsim.to/c/liveries/airbus-h160/>. Please do share your liveries with the community.

## Paint Kit

[Download Official Paint Kit \(Version 2\)](#)

- You may also find these community resources helpful:
- Livery starter templates: <https://flightsim.to/file/62762/hpg-h160-livery-paintkit>  
Getting started with liveries for MSFS: <https://www.youtube.com/watch?v=3atVWEEITQ0>

## Selecting Variant

Your livery aircraft.cfg base\_container should point to

Luxury (Base Pack)	hpg-airbus-h160
Civilian (Base Pack)	hpg-airbus-h160-civ

Texture.cfg (Luxury)

```
[fltsim]
fallback.1=..\..\hpg-airbus-h160\texture
```

Texture.cfg (Civilian)

```
[fltsim]
fallback.1=..\..\hpg-airbus-h160-civ\texture
fallback.2=..\..\hpg-airbus-h160\texture
```

## Controlling External Parts

In order to control the parts for your livery, you must include a new file within your livery package named `Livery\<Title>.json`. Change only **<Title>** to match your aircraft. The **<Title>** comes from your `aircraft.cfg, fltsim.0 title=<Title>` line. For example the built-in package uses a configuration for the livery matching the title **Airbus H160 Civilian Livery 2**.

## Sample Configuration

```
{
  "Commands": [
    {"Name": "H160_WSPS_Top", "Value": 1},
    {"Name": "H160_WSPS_Bottom", "Value": 1},
    {"Name": "H160_WSPS_Skids", "Value": 1},
    {"Name": "H160_SkidSettlingPreventers", "Value": 1},
    {"Name": "H160_Radome", "Value": 1}
  ],
  "CrewTitle": "Airbus H160 Example Crew"
}
```

**NOTE:** Invalid JSON will be rejected. Use [JSON Validator](#) to check your file

Command	Values	Notes
H160_WSPS_Top H160_WSPS_Bottom H160_WSPS_Skids	0 or 1	Wire Strike Protection system options. <b>Bottom WSPS not available on Military variant.</b>
H160_SkidSettlingPreventers	0 or 1	Skid-settling-preventers presence. Not compatible with skid snow skis.
H160_SkidStrutCaps	0 or 1	Skid strut covers near cockpit door
H160_SECOND_LANDING_LIGHT	0 or 1	Add a second fixed LDG light
H160_ROTOR_BLUR_STRIPES	0 or 1	Turn on rotor visuals with a split top and bottom texture, better for rotor designs where the top has stripes but the bottom is black.

## Configuring external crew

To set the crew models which appear detached from the helicopter, you can use the CrewTitle token to select any of the default crews that come with H145. **Action Pack only.**

Title	Description
Airbus H160 ADAC Crew	ADAC style
Airbus H160 DRF Crew	DRF style
Airbus H160 CMH Crew	Generic red style
Airbus H160 Norsk Luftambulanse Crew Airbus H160 HeliOtago Crew Airbus H160 Bundeswehr Crew	Generic orange style
Airbus H160 CAL FIRE Crew	CAL FIRE style

## Custom external crew

If you paint the crew models you must include a second `aircraft.cfg` which points to the crew base container. The second `aircraft.cfg` is based on `hpg-airbus-h160-crew` and should have a `texture.cfg` which points to your aircraft main livery texture folder. There is no need to duplicate any textures, you will simply add one more `aircraft.cfg` and `texture.cfg` to your livery package. The CrewTitle should then be set to your crew livery name, which is recommended to be in the form of `YourLiveryTitle Crew`

## Setting Tablet Wallpaper

Include a **wallpaper.jpg** file in your package: `html_ui\Livery\<Title>\wallpaper.jpg`

## Adding documents to the Documents app

Your livery may add documents to the Documents app. They will be merged in with the documents provided by the system and the user.

1. See the Documents app section for how to generate user documents.
2. Move everything (including Index.json) in: `hpg-airbus-h160-userdocs\html_ui\HPGH160-User\Documents`  
To: `<your livery>\html_ui\HPGH160-User\LiveryDocuments\<livery title>`

## Download and Install H160

If you already have installed on MSFS 2020, refer to [Copy & Install](#) below.

If you are installing from the pinned messages (Discord), see "[Install download.](#)"

### Download & Install

Install either H145 or H160 using this guide.

1. Download and install [Hype Operations Center](#).



2. Open Hype Operations Center from your Start menu.
3. Visit the product page (either H145 or H160) for the aircraft you'd like to install.

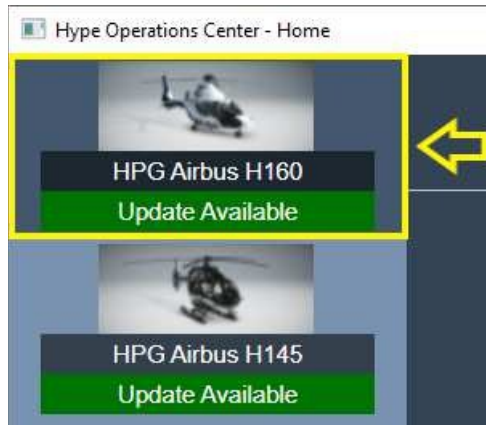

4. Click to select the Community path. (see [How do I find the community folder?](#))

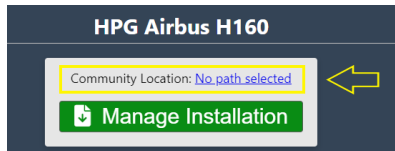

5. Select your Community location. The item must show as highlighted in blue. You may select a custom path for use with Addon Linker, or if the automatic detection is not correct.

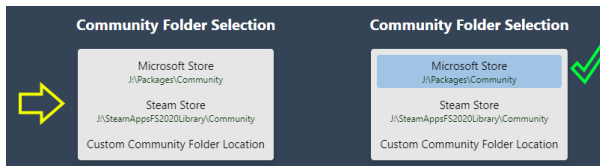

6. Select your aircraft from the side menu again.



7. Confirm the Community location is correct, and then click Manage Installation.

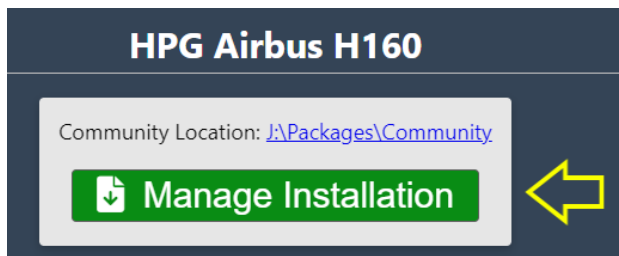

8. Enter your Base Pack license key. You will have been emailed this from Hype Performance Group Downloads. [Help me find my details!](#)



9. Copy & Paste your license key into the box. The green ADD button will be available only when the correct length key is entered. Check for extra spaces before or after the key, if you have trouble.

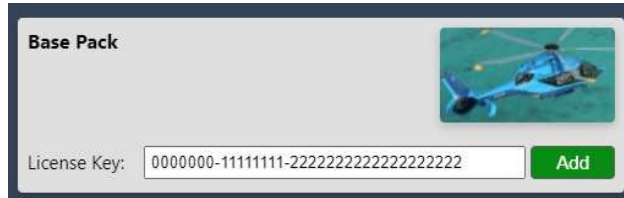

10. The key has been entered successfully.

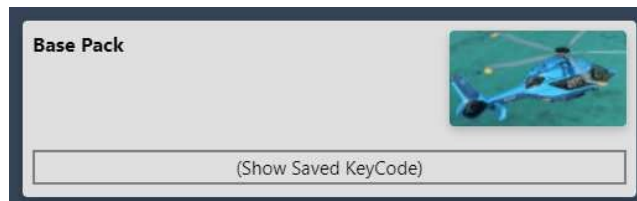

11. Select a version for installation. Usually the top-most version is best.



12. Wait for download and installation.



13. Check for installation success. You are ready to fly.

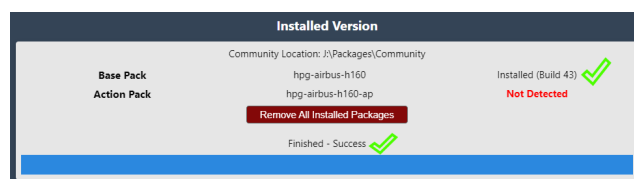

14. Activation for MSFS 2024. Workaround for SU2

- Close MSFS 2024
- Download MSFSLayoutgenerator.exe from GitHub: <https://github.com/HughesMDflyer4/MSFSLayoutGenerator/releases/download/v1.1.1/MSFSLayoutGenerator.exe>
- Locate your Community folder
- Drag the layout .json file from the hpg-airbus-h160 directory onto the downloaded .exe file

The 4 most common mistakes we see here are:

- 1 - Duplicate Community folders and paths not correct
- 2 - Opening or running MSFSLayoutGenerator (DON'T!)
- 3 - Trying to modify .json files while FS24 is running. Close first, then restart the sim after mods.
- 4 - Copying or moving the layout.json files before dragging them over LoG. They must be grabbed from their home location in the HPG folder structure so LoG can do its voodoo magic. If LoG senses the .json files come from another location, it will do it's comparative analysis from that location and will fail in its function

## Copy & Install

If you have installed the H160 on MSFS 2020 you can copy the H160 folder to MSFS 2024. Copy the following folders (as applicable):

- hpg-airbus-h160
- hpg-airbus-h160-usersetup
- hpg-hatws-data ([download here](#))
- pms50-instrument-gtn750 ([download here](#))

## How to Install test version

To install a test version join the H160/H145-discussion our Discord server, go to the pinned messages and download the last Build. Manually unpack the zip-file and copy the files to Community. If you do it correctly then you will be asked to overwrite the files and you must answer yes. HOC will report the new build once installed.

## Installation with the download file from Discord

First, try the normal installation. If that does not work, even though it was performed correctly, you can perform the manual installation. Please close FlightSimulator before installation. According to HPG, the following steps are necessary for installation

- Download the [file from Google Drive](#).
- Unzip the file into the Community folder.
- Open the file community\hpg-airbus-h160\html\_ui\HPGH160-System\product.json with a text editor and enter your license key there (please delete the number entered there).

After that, you can start the simulator and should be able to fly the H160.

## HOW to Install HTAWS Database

To install the local HTAWS Database join the H160/H145-discussion our Discord server, go to the pinned messages and download the hpg-htaws-data.zip or use this link <https://drive.google.com/file/d/1eMd6cjDGPValm4CBajPVXmtnBG-L4k1z/view?usp=sharing> Copy the folder included in the .zip file to your Community folder. You need to do this once for H160 and H1145.

## How to Install Action Pack

To install Action Pack, follow these steps:

1. Add the Action Pack license key (use steps 8-10 from the procedure above)
2. After the Action Pack key is saved, select **Remove all installed packages**
3. Select **Install** on a version from the available versions list

Now Action Pack will be downloaded and installed along with a matched version of the Base Pack.

Note: Action Pack is coming soon.

## After Installation

- Upgrading to a new version does not require uninstall, however rolling back to an earlier version does.
- To use an older version, click Remove all packages and then Install. You may need to reveal all versions by selecting Show Hidden Versions

### Download Cache

ZIP files are cached to %appdata%\Hype Aircraft\Downloads. You may clear this directory as needed and the large files will be re-downloaded, however this may be slow. You may also junction this location to another drive if needed.

Products are composed of a main package (large) and an update package (much smaller). Keeping the main package will allow you to avoid any extra download time when changing builds (specifically rolling back or reinstalling).

### Use of Addon Linker

Use of the third party program Addon Linker is supported: you should place all of your HPG addons into one folder somewhere, and then point Hype Operations Center to that folder as if it was your Community location. Then link in your content as normally in addon linker.

Note that Hype Operations Center assumes it can find content like mission packs by navigating to other folders in your selected Community Location. For this reason you should place HPG addons, mission packs and object packs into one combined location so that Hype Operations Center sees it as a 'normal Community folder'.

### Activation trouble

Activation is on Microsoft Azure and highly reliable. If you have trouble activating in the cockpit, check these items (the most likely listed first):

- Check that **Online Functionality** is enabled in MSFS DATA Settings
- Ensure that your PC Date, Time and Timezone are accurate. Go into PC Settings to update your PC time. **Set time automatically** is highly recommended.
- Check your firewall. You must be able to access [This URL \(opens new window\)](#). You should see **Not Authorized**.
- Reinstall the aircraft to ensure that you don't have a corrupt copy installed.
- Remove all other addons from your Community folder
- Remove addons from exe.xml

## Troubleshooting

### Microsoft Teams or other app won't install

The Squirrel installer has [a bug](#) where it can confuse itself with stale data. You may see Microsoft Teams by Hype Performance Group.

Resolution:

1. Open %LocalAppData%\SquirrelTemp in the File Explorer address bar.
2. Delete SquirrelTemp folder.
3. Attempt installation again (of Hype Operations Center or another Squirrel installer).

## Known Issues

Issue	Workaround
Error: path is not absolute	Community Location was not properly set, re-select the Community Location and try again
Error: end of central directory index	Visit Settings -> Download Cache Location. Delete the small zip file (13kb or so) and try again

We are working to remove known issues and above will all be fixed in a subsequent update.

## How are helicopter buttons configured?

With the MSFS you can easily assign buttons to functions. As with other vehicles, this is done in the Flight Simulator options. However, this can be somewhat “difficult” if you have to search for the correct functions or if no or unknown functions are used for individual buttons. The HYPE helicopters have a function for each button that can be assigned as required, even if a corresponding function is missing in the MSFS. In general, this is done by using unused functions of the MSFS using the Hype Operations Center. The assignments of pre-assigned functions can also be found here. The procedure is identical for the H145 and the H160. In general, you should think about the functions you want to have on the sticks and their buttons on the controllers beforehand. Which functions do I need? How easy is it to reach the buttons/switches/...? It is also helpful to record the assignment on a picture and place it in the user docs. You can have a quick look here during the flight.



### Normal assignment

Known functions are assigned to individual buttons in the MSFS options. You probably know the procedure well by now, but here it is again for the sake of completeness.

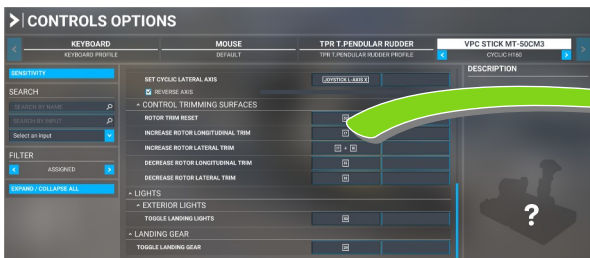

The whole thing is made even easier by the fact that you only have to press the button when selecting. So select the desired function in the MSFS, click in the assignment field and press the desired button when the “Select input” function is selected.

### Assignment with HOC

If the desired function of the helicopter is not included in the functions of the MSFS, the Hype Operations Center is required. Here, the required function is assigned to an unused function of the MSFS and can then be assigned to a button as shown above.

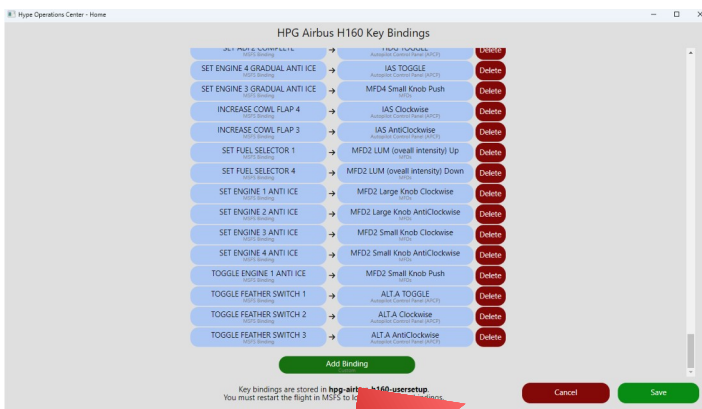

In the helicopter, you will find the Keybindings assignments, click on “Add Binding”.

item. All standard assignments are already defined in the upper area. For your own function

The MSFS functions can be found on the left and the helicopter functions on the right.

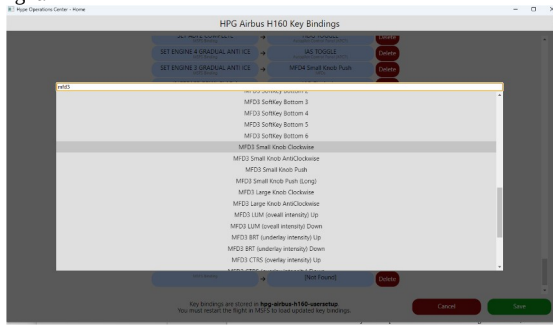
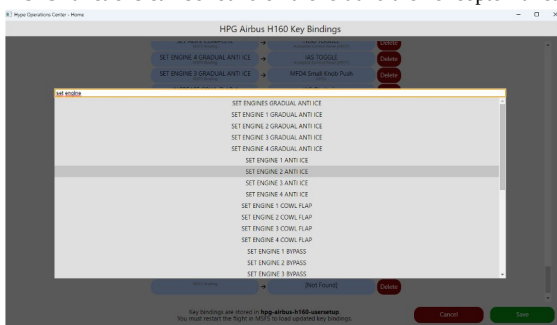

Simply select the function, save it and the function can be assigned to a button in the MSFS. Note, however, that the flight must be restarted for a new assignment!

## How do I assign a stream deck?

In general, buttons or controls (Stream Deck +) are assigned in exactly the same way as normal buttons. However, there is an additional step with the Stream Deck SW.

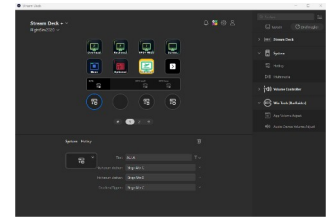

Here again, the desired helicopter function is first assigned to an MSFS function. Then assign the function to a free key combination in the MSFS and finally assign it to the desired key or, as in the example here, to a knob in the Stream Deck software.

## Tips and tricks

### How do I find the community folder?

Here are two methods to find the community folder:

#### In Developer Mode

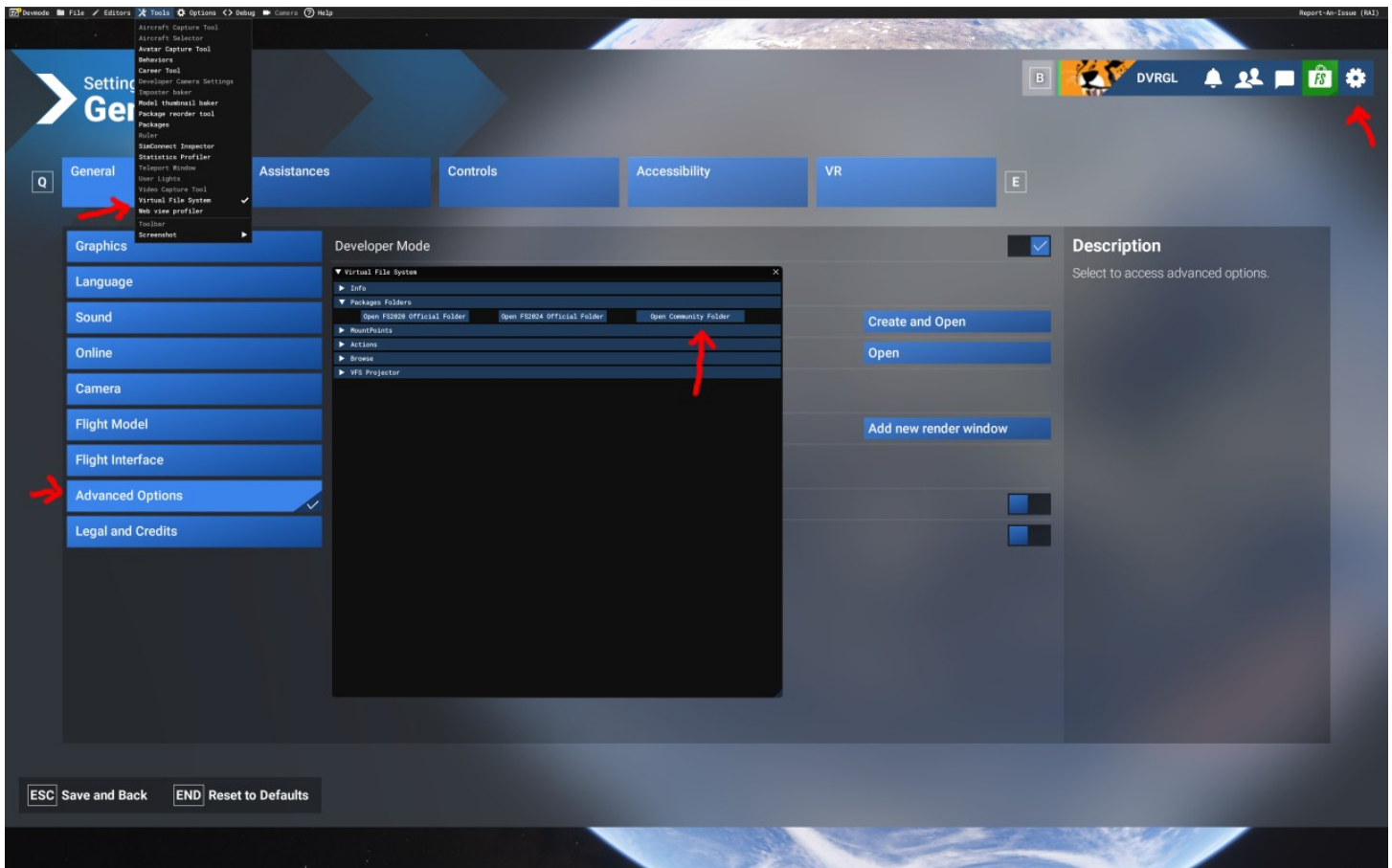

- Launch Microsoft Flight Simulator
- Go to Options → General Options
- Enable Developer Mode by clicking on the Developers tab and setting Developer Mode to On
- In the new menu bar at the top of the screen, click Tools → Virtual File System
- Expand "Packages Folders"
- Click "Open Community Folder"
- This method works regardless of how you installed MSFS and is the most reliable way to locate the correct folder

## In the settings

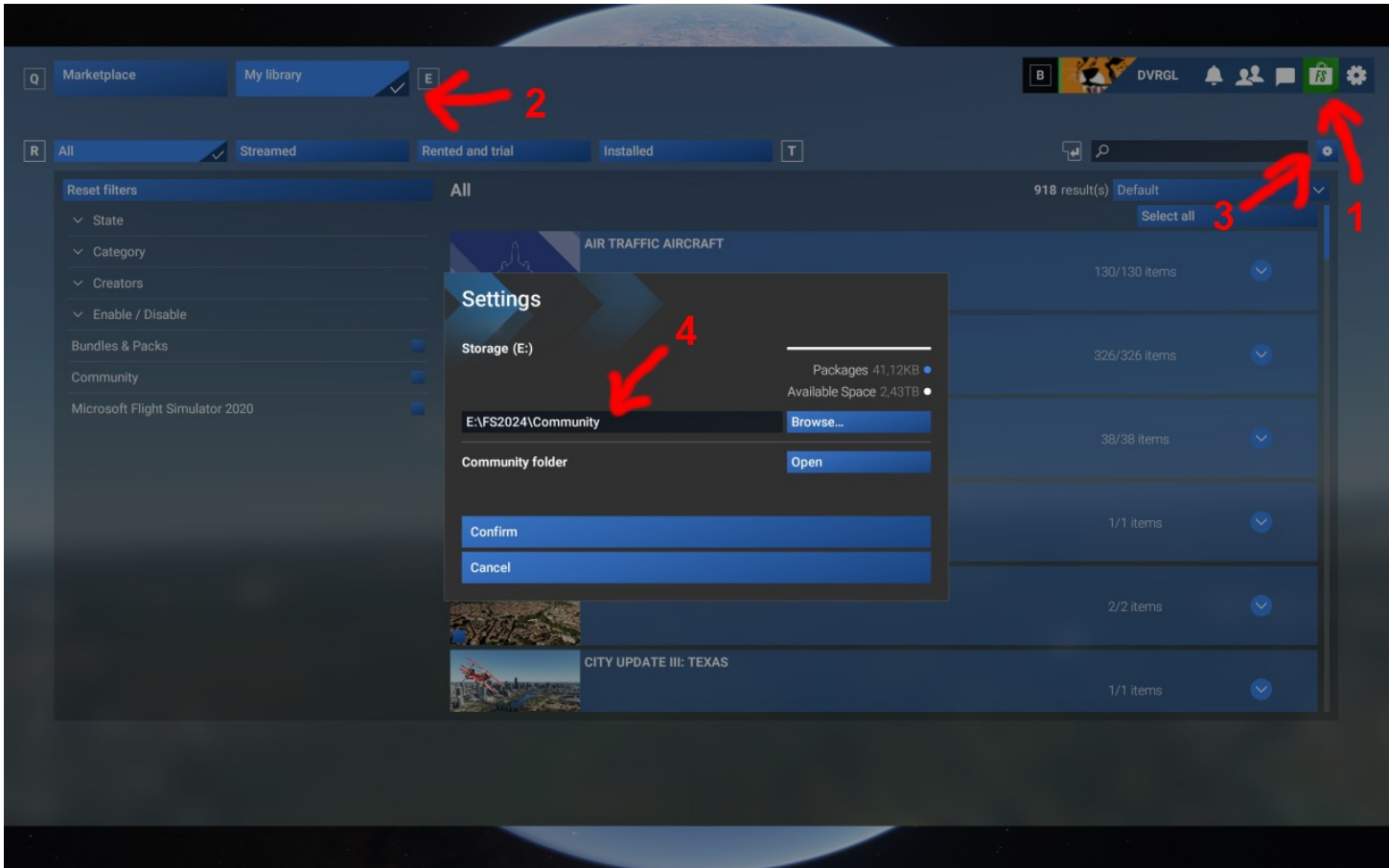

- Start Microsoft Flight Simulator
- Click on the Marketplace at the top right
- Click on "My Library" at the top left
- Click on the cogwheel on the right
- In the settings you will find or can set the folder

## GTC and how it works

### GTC at low speed (like hover):

cyclic beep: up/down: forward/backward longitudinal speed (ground speed)  
 cyclic beep: left/right: left/right lateral speed (ground speed)  
 collective beep left/right: heading reference

### GTC at high speed:

cyclic beep: up/down: forward/backward longitudinal speed (ground speed)  
 cyclic beep: left/right: heading reference  
 collective beep left/right: no function

## HANDS ON detection setting

### None:

This means that your stick is always active but you should use Trim Release to really take control otherwise the AFCS will be fighting you the entire time. Note that in this setting, L:FFB\_HANDS\_ON\_CYCLIC or L:FFB\_HANDS\_ON\_CYCLICY/L:FFB\_HANDS\_ON\_CYCLICX can be used to provide CSAS signal.

### Motion Rate

This uses motion rate detection (with a slider to adjust sensitivity). When you move the stick it goes into CSAS modes automatically, which is similar to using trim release and more like the 1.0 flight model

### Deadzone

This is the traditional deadzone that has been an option for a long time.

### Ignore

This is the old AFCS Override: AP Only setting, where your stick is ignored unless you press Trim Release. This is good for people without friction locks or people who absolutely demand it works like the Asobo autopilot.

## Trim release

The understanding and correct use of trim release always is a problem. FireHawk wrote a short explanation in the Discord H160\_discussion. This is for the H145 correct too.

When your Automated Flight Control System (AFCS) is turned on (all "OFF" indicators not showing on the AFCS panel) this is what's called Attitude Mode (ATT). In ATT, the aircraft will always want to hold pitch and roll axis (nose up/down and roll right/left) where you last left them when, basically, you take your hands off the stick. So, let's say you're hands off, flying 120kts, straight-n-level. You see some birds ahead, so you grab the cyclic and roll right to avoid them. When you release the stick, it will roll left back to level on its own. Same for pitch.

Now, doing the same exercise, S-n-L, 120kts, except this time press and hold Trim Release (TR) while you roll right. When you're banked over, release TR and the cyclic and now the aircraft will hold that bank angle (that Attitude). So wherever your nose is pointed or tilted, if you move the stick, the aircraft will 'rubber-band' right back to where it was. Press TR, move the stick, release TR and now you've centered the rubber bands (as it were). Also, Force Trim Release is NOT the same as Beep Trim. Beep Trim lets you move those ATT set points small 'beeps' at a time. Beep Trim functions kinda similar to a fixed-wing elevator or aileron trim system in feel (but is a different function mechanically).

## Difference between 'trim release' and 'spring override'

The indication OVERRIDE is used for two different notifications.

- 1- When using Trim Release in ATT Mode (TR), the override is telling you that you are overriding the AFCS system and the 'trims' are disengaged but following your stick movement. When you release TR, the servos are now positioned to that new set point for hands off (or hands light) control of the cyclic.
  - 2- When in ATT or Upper Modes, and you don't use TR when moving the cyclic, OVERRIDE is telling you that you are 'pushing against springs'. The servos remain at their set points, and when you release the cyclic, the aircraft will want to return to those set points or UM settings.
- Let's say you are on final approach (ATT Mode) to your LZ and you encounter a flock of birds. You roll right to avoid the birds, roll left back on course and when you let go (or go light touch), the ATT set points are still where they were before.

## Correct setting of Trim Release

One source of problems is the correct setting and application of Trim Release button. Dave described this as follows in the H145 discussion forum:

The types of cyclic controls are:

Spring joystick (centering spring)

- no-spring helicopter controls (friction lock available). may or may not have light spring forces.
- no-spring helicopter controls (friction lock NOT available)
- Keyboard or controller buttons. This is difficult and rare.
- Full FFB cyclic. This is pretty rare.

In every case below you'll want to use zero deadzone in MSFS settings.

### spring joystick:

Cyclic trim system: software (default setting)

HANDS ON detection strategy: deadzone (default setting)

Follow-up trim: HOVER or BOTH (default setting)

In this configuration you'll have the virtual trim (blue cross) constantly moving to relax your stick position. It's slow so it shouldn't bother you, but it means no matter if you are in cruise or in hover, the stick will slowly relax so you are at zero forces.

Follow-up trim should either be in HOVER or BOTH modes. When you are in ATT mode (blank on the MFD) you can bump the stick and have either "fly back to previous setpoints" or it can "sync to current" to where the aircraft ends up. Follow-up trim depends on HANDS ON detection strategy. The real aircraft will use HOVER only. (Helionix V10 adds TAC mode which is a follow-up trim for cruise).

**IMPORTANT:** The deadzone strategy for detecting HANDS ON means we expect your stick to reliably re-center itself and you should set a deadzone which is large enough such that you don't have spurious HANDS ON events when you actually are not manipulating the stick.

You have the option (not recommended) of using the DCS-style center-displacement binding. You'll need to switch the cyclic trim system is on hardware as it would compete with the displacement binding.

Add a control binding for MAGNETO 2 START (default binding)

When your control is in a desirable position. click the binding

Your cyclic is now disconnected. Within the Center displace reset time setting time, you must return your stick to a center position.

Your controls will now be reconnected, but you moved them into the neutral position, so there is no change in output since step 2.

This strategy of updating the center position is common on other sims like DCS or the xplane rotorsim EC135, although we believe the Trim Release strategy works better without interruption to the controls.

### no-spring or helicopter cyclic:

Cyclic trim system: Hardware

Follow-up trim: BOTH

Friction Lock available:

HANDS ON detection strategy: Motion

Friction Lock not available:

HANDS ON detection strategy: Ignore

The cyclic virtual trim will not be available, which means your stick is always directly connected to the helicopter output without an offset provided by the trim. As a consequence you'll need to deflect your stick forward in cruise as with any other helicopter. You can enable the software trim system and make use of the virtual trim if you prefer.

Motion HANDS ON detection strategy is necessary for HANDS ON detection because the deadzone is unlikely to be usable due to lack of a centering force. If you can return your stick reliably to the center, you may like to use the centering-spring settings entirely. If the Motion strategy doesn't work well for you, then NONE could be used, along with heavy Trim Release use.

If your control cannot be parked in a position, you'll not be able to use the AFCS unless you use the Ignore strategy for HANDS on detection. Using the Ignore mode means that your stick position will be completely ignored except when you use Trim Release. By this method you may use beep trim and UPPER MODES, while your cyclic is deflected to one corner or in any position.

Follow-up trim is recommended to be on the BOTH setting to avoid the AFCS fighting you. Since your stick is always directly connected, your hand holding it would prevent fly-back behavior and as such it's probably better to just avoid the AFCS trying to fly back regardless.

**Force Feedback cyclic:**

Cyclic trim system: Hardware  
 Follow-up trim: BOTH  
 HANDS ON detection strategy: None

FFB controllers will monitor SEMA L:Vars and drive trim motors to de-saturate them, so virtual trim must be disabled.

Follow-up trim should be on BOTH for the reasons mentioned above around avoiding AFCS fly-back.

HANDS ON detection strategy should be None to disable built-in CSAS modes. CSAS detection signal must be provided by L:Var. If you cannot provided CSAS signal then Trim Release should be used.

**How to make an approach:**

Many pilots think in terms of vertical flight, but a 3-ton aircraft of any wing type (rotor or fixed) generally requires a bit more horizontal thought process. As you approach your landing zone (starting about 3 to 4 miles out, depending on altitude) pitch the nose up to start scrubbing speed and reduce collective to start descending. Look for around 50 to 60 knots and use the collective to keep your LZ steady in your sight picture... not climbing in your windscreen, or falling. As you get closer, the idea is to keep above 30 kts forward speed so the rotor disc continues to act as a total airfoil. The goal then is to scrub speed and altitude so as to end up at zero speed, zero descent, and about 10 feet in hover (that puts you hovering in ground effect.. HIGE) all at the same time. Now, stabilize hover and slowly work the collective until skids/wheels are on the ground. Practice, practice, practice until you find the muscle memory, then it will all come together for you.

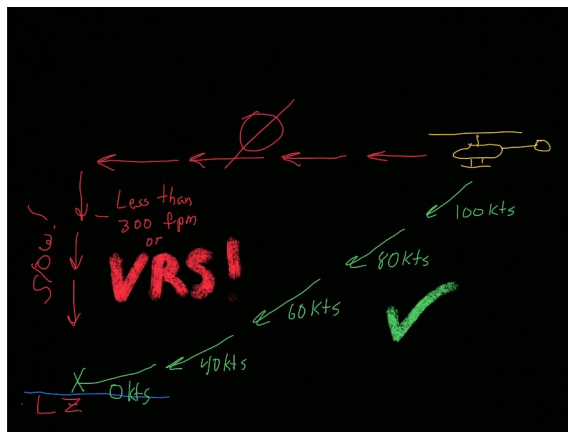

(Thx. To FireHawk)

**I have installed 2024 or switched to it and cannot find the standard HPG livery (anymore).**

2024 organisiert die Livery anders als 2020. Die Livery finden sich in der Flugzeugauswahl (Modell wählen) hinter der Funktion "F Configure" oder einfach durch drücken der Taste "F".

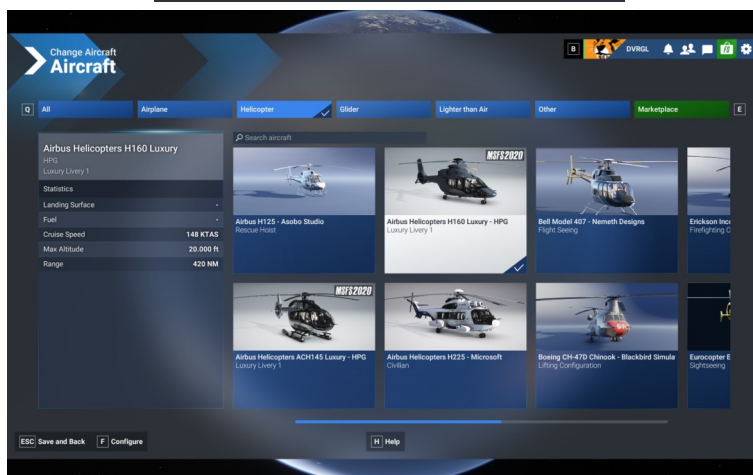
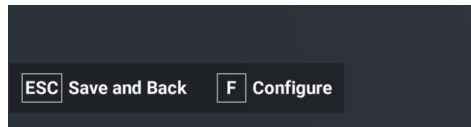

## How can I integrate night vision?

Since FS 2024 SU4, night vision has been built in as standard. It only needs to be activated in the aircraft and the switches set up.

To set it up, open the directory  
 /Community\hpg-airbus-h160\Simobjects\Airplanes\hpg-airbus-h160-civ  
 and locate the file system.cfg. Open it with an editor and scroll all the way down. Insert the following lines here:

```
[NIGHT_VISION]
Available = true
Intensity = 300
```

Save the file, start the simulator, and enter the necessary key assignments.



night vision		Search by input	All
NIGHT VISION DISPLAY OFF	Helicopters	Digital	
NIGHT VISION DISPLAY ON	Helicopters	Digital	
NIGHT VISION DISPLAY SET	Helicopters	Digital	
NIGHT VISION DISPLAY TOGGLE	Helicopters	Digital	8
NIGHT VISION INTENSITY DEC	Helicopters	Digital	10
NIGHT VISION INTENSITY INC	Helicopters	Digital	12
NIGHT VISION INTENSITY SET	Helicopters	Digital	

## What can I do if OSM stops providing map data for the DMAP?

You can register for free at <https://cloud.maptiler.com/> and will then receive your [private API key](#), which allows you to access all types of raster maps (including OSM) using the free quota—that should be more than enough.

Next, go to the directory ..\Community\hpg-airbus-h160\html\_ui\HPGH160-User\MFD\ and insert the following lines into the DMAP.json file:

```
{
  "title": "VECTOR",
  "url": "https://api.maptiler.com/maps/openstreetmap/{z}/{x}/{y}.png?key=*****",
  "tileSize": 512,
  "zoomOffset": -1,
  "attributions": "&copy; OpenStreetMap contributors"
}
```



Thanks for the tip to @Daikan (Discord). A donation to [OpenStreetMap](#) wouldn't hurt either.

## SDK H:Events

### Home Cockpit SDK

See [hpg-airbus-h160\html\\_ui\HPGH160-System\H160\\_Keys.txt](hpg-airbus-h160\html_ui\HPGH160-System\H160_Keys.txt) for a full listing of events for your build.  
 H:Events or Html Events may be used with tools like FSUIPC and SPAD.NEXT.

### Overhead Panel

#### Overhead Panel

Name	Event
Generator 1 OFF	H:H160_SDK_OH_GEN_1_OFF
Generator 1 RESET	H:H160_SDK_OH_GEN_1_RESET
Generator 2 ON	H:H160_SDK_OH_GEN_2_ON
Generator 2 OFF	H:H160_SDK_OH_GEN_2_OFF
Generator 2 RESET	H:H160_SDK_OH_GEN_2_RESET
Emergency Generator OFF	H:H160_SDK_OH_EGEN_OFF
Emergency Generator ON	H:H160_SDK_OH_EGEN_ON
Emergency Generator TOGGLE	H:H160_SDK_OH_EGEN_TOGGLE
Electical Cut	H:H160_SDK_OH_ELEC_CUTOFF_OFF
Electical Cut	H:H160_SDK_OH_ELEC_CUTOFF_ON
Electical Cut	H:H160_SDK_OH_ELEC_CUTOFF_TOGGLE
Electical ALT1 OFF	H:H160_SDK_OH_ELEC_ALT1_OFF
Electical ALT1 ON	H:H160_SDK_OH_ELEC_ALT1_ON
Electical ALT1 TOGGLE	H:H160_SDK_OH_ELEC_ALT1_TOGGLE
Electical ALT2 OFF	H:H160_SDK_OH_ELEC_ALT2_OFF
Electical ALT2 ON	H:H160_SDK_OH_ELEC_ALT2_ON
Electical ALT2 TOGGLE	H:H160_SDK_OH_ELEC_ALT2_TOGGLE
Battery 1 OFF	H:H160_SDK_OH_BAT_1_OFF
Battery 1 ON	H:H160_SDK_OH_BAT_1_ON
Battery 1 RESET	H:H160_SDK_OH_BAT_1_RESET
Battery 2 OFF	H:H160_SDK_OH_BAT_2_OFF
Battery 2 ON	H:H160_SDK_OH_BAT_2_ON
Battery 2 RESET	H:H160_SDK_OH_BAT_2_RESET
TEST PREFLIGHT	H:H160_SDK_OH_LAMP_TEST_PREFLIGHT
TEST OFF	H:H160_SDK_OH_LAMP_TEST_OFF
TEST LAMP	H:H160_SDK_OH_LAMP_TEST_LAMP
RA1 ON	H:H160_SDK_OH_RA1_ON
RA1 OFF	H:H160_SDK_OH_RA1_OFF
RA1 TOGGLE	H:H160_SDK_OH_RA1_TOGGLE
RA2 ON	H:H160_SDK_OH_RA2_ON
RA2 OFF	H:H160_SDK_OH_RA2_OFF
RA2 TOGGLE	H:H160_SDK_OH_RA2_TOGGLE
HIGH NR ON	H:H160_SDK_OH_HIGH_NR_ON
HIGH NR OFF	H:H160_SDK_OH_HIGH_NR_OFF
HIGH NR TOGGLE	H:H160_SDK_OH_HIGH_NR_TOGGLE
Emergency Floats OFF	H:H160_SDK_OH_EMER_FLOATS_OFF
Emergency Floats ARM	H:H160_SDK_OH_EMER_FLOATS_ARM
Emergency Floats TEST	H:H160_SDK_OH_EMER_FLOATS_TEST
Fuzz Burner OFF	H:H160_SDK_OH_FUZZ_CHIP_BURNER_OFF
Fuzz Burner ON	H:H160_SDK_OH_FUZZ_CHIP_BURNER_ON
Windshield Wiper OFF	H:H160_SDK_OH_WINDSHIELD_WIPER_OFF
Windshield Wiper SLOW	H:H160_SDK_OH_WINDSHIELD_WIPER_SLOW
Windshield Wiper FAST	H:H160_SDK_OH_WINDSHIELD_WIPER_FAST
Air Conditioning OFF	H:H160_SDK_OH_AIR_CONDITIONING_OFF
Air Conditioning ON	H:H160_SDK_OH_AIR_CONDITIONING_ON
Cockpit Vent OFF	H:H160_SDK_OH_COCKPIT_VENT_OFF
Cockpit Vent ON	H:H160_SDK_OH_COCKPIT_VENT_ON

IBF 1 CLOSED	H:H160_SDK_OH_IBF_1_CLOSED
IBF 1 OPEN	H:H160_SDK_OH_IBF_1_OPEN
IBF 2 CLOSED	H:H160_SDK_OH_IBF_2_CLOSED
IBF 2 OPEN	H:H160_SDK_OH_IBF_2_OPEN
ACAS MUTE	H:H160_SDK_OH_AUDIO_ACAS_MUTE
ACAS NORMAL	H:H160_SDK_OH_AUDIO_ACAS_NORMAL
HTAWS MUTE	H:H160_SDK_OH_AUDIO HTAWS_MUTE
HTAWS MUTE	H:H160_SDK_OH_AUDIO HTAWS_MUTE_5MIN
HTAWS NORMAL	H:H160_SDK_OH_AUDIO HTAWS_NORMAL
HTAWS STANDBY	H:H160_SDK_OH_AUDIO HTAWS_STANDBY
Int Lights Cargo/Pax OFF	H:H160_SDK_OH_INT_LIGHT_CARGO_PAX_OFF
Int Lights Cargo/Pax PAX	H:H160_SDK_OH_INT_LIGHT_CARGO_PAX_PAX
Int Lights Cargo/Pax BOTH	H:H160_SDK_OH_INT_LIGHT_CARGO_PAX_ON
Int Emergency Exits OFF	H:H160_SDK_OH_INT_LIGHT_EMERGENCY_EXITS_OFF
Int Emergency Exits ARM	H:H160_SDK_OH_INT_LIGHT_EMERGENCY_EXITS_ARM
Int Emergency Exits ON	H:H160_SDK_OH_INT_LIGHT_EMERGENCY_EXITS_ON
Int Panel Lights DAY	H:H160_SDK_OH_INT_LIGHT_INSTRUMENT_PANEL_DAY
Int Panel Lights NIGHT	H:H160_SDK_OH_INT_LIGHT_INSTRUMENT_PANEL_NIGHT
Int Panel Lights NVG	H:H160_SDK_OH_INT_LIGHT_INSTRUMENT_PANEL_NVG
Ext Lights HISL ON	H:H160_SDK_OH_EXT_LIGHT_HISL_ON
Ext Lights HISL OFF	H:H160_SDK_OH_EXT_LIGHT_HISL_OFF
Ext Lights HISL TOGGLE	H:H160_SDK_OH_EXT_LIGHT_HISL_TOGGLE
Cockpit Vent INCREASE	H:H160_SDK_OH_COCKPIT_VENT_POT_INC
Cockpit Vent DECREASE	H:H160_SDK_OH_COCKPIT_VENT_POT_DEC
Panel Lights INCREASE	H:H160_SDK_OH_INT_LIGHT_INSTRUMENT_PANEL_KNOB_INC
Panel Lights DECREASE	H:H160_SDK_OH_INT_LIGHT_INSTRUMENT_PANEL_KNOB_DEC
Center Light TOGGLE	H:H160_SDK_OH_COCKPIT_LIGHT_CENTER_TOGGLE
Center Light ON	H:H160_SDK_OH_COCKPIT_LIGHT_CENTER_ON
Center Light OFF	H:H160_SDK_OH_COCKPIT_LIGHT_CENTER_OFF
Left Light TOGGLE	H:H160_SDK_OH_COCKPIT_LIGHT_LEFT_TOGGLE
Left Light ON	H:H160_SDK_OH_COCKPIT_LIGHT_LEFT_ON
Left Light OFF	H:H160_SDK_OH_COCKPIT_LIGHT_LEFT_OFF
Right Light TOGGLE	H:H160_SDK_OH_COCKPIT_LIGHT_RIGHT_TOGGLE
Right Light ON	H:H160_SDK_OH_COCKPIT_LIGHT_RIGHT_ON
Right Light OFF	H:H160_SDK_OH_COCKPIT_LIGHT_RIGHT_OFF
AUX HYD PUMP ON	H:H160_SDK_OH_AUX_HYD_ON
AUX HYD PUMP OFF	H:H160_SDK_OH_AUX_HYD_OFF
AUX HYD PUMP TOGGLE	H:H160_SDK_OH_AUX_HYD_TOGGLE

### Engine Control Panel (ECP)

Name	Event
Toggle both engines FLIGHT/IDLE	H:H160_SDK_ECP_FADEC_DUAL_TOGGLE
Main 1 FLIGHT	H:H160_SDK_ECP_MAIN_1_FLIGHT
Main 1 IDLE	H:H160_SDK_ECP_MAIN_1_IDLE
Main 1 OFF	H:H160_SDK_ECP_MAIN_1_OFF
Main 1 UP	H:H160_SDK_ECP_MAIN_1_UP
Main 1 DOWN	H:H160_SDK_ECP_MAIN_1_DOWN
Main 2 FLIGHT	H:H160_SDK_ECP_MAIN_2_FLIGHT
Main 2 IDLE	H:H160_SDK_ECP_MAIN_2_IDLE
Main 2 OFF	H:H160_SDK_ECP_MAIN_2_OFF
Main 2 DOWN	H:H160_SDK_ECP_MAIN_2_DOWN
Main 2 UP	H:H160_SDK_ECP_MAIN_2_UP
Main 1 Latch OFF	H:H160_SDK_ECP_MAIN_LATCH_1_OFF
Main 1 Latch ON	H:H160_SDK_ECP_MAIN_LATCH_1_ON
Main 2 Latch OFF	H:H160_SDK_ECP_MAIN_LATCH_2_OFF
Main 2 Latch ON	H:H160_SDK_ECP_MAIN_LATCH_2_ON

**Autopilot Control Panel (APCP)**

Name	Event
A.TRIM TOGGLE	H:H160_SDK_APCP_ATRIM_TOGGLE
A.TRIM ON	H:H160_SDK_APCP_ATRIM_ON
A.TRIM OFF	H:H160_SDK_APCP_ATRIM_OFF
AP1 TOGGLE	H:H160_SDK_APCP_AP1_TOGGLE
AP1 ON	H:H160_SDK_APCP_AP1_ON
AP1 OFF	H:H160_SDK_APCP_AP1_OFF
AP2 TOGGLE	H:H160_SDK_APCP_AP2_TOGGLE
AP2 ON	H:H160_SDK_APCP_AP2_ON
AP2 OFF	H:H160_SDK_APCP_AP2_OFF
BKUP TOGGLE	H:H160_SDK_APCP_BKUP_TOGGLE
BKUP ON	H:H160_SDK_APCP_BKUP_ON
BKUP OFF	H:H160_SDK_APCP_BKUP_OFF
ALT TOGGLE	H:H160_SDK_APCP_ALT_TOGGLE
ALT ON	H:H160_SDK_APCP_ALT_ON
ALT OFF	H:H160_SDK_APCP_ALT_OFF
(VS/FPA HDG/TRK) TOGGLE	H:H160_SDK_APCP_GPSMODE_TOGGLE
(VS/FPA HDG/TRK) VS/HDG	H:H160_SDK_APCP_GPSMODE_TRAD
(VS/FPA HDG/TRK) TRK/FPA	H:H160_SDK_APCP_GPSMODE_GPS
ALT.A TOGGLE	H:H160_SDK_APCP_ALTA_TOGGLE
ALT.A ON	H:H160_SDK_APCP_ALTA_ON
ALT.A OFF	H:H160_SDK_APCP_ALTA_OFF
ALT.A Clockwise	H:H160_SDK_APCP_ALTA_Clockwise
ALT.A AntiClockwise	H:H160_SDK_APCP_ALTA_AntiClockwise
CR.HT TOGGLE	H:H160_SDK_APCP_CRHT_TOGGLE
CR.HT ON	H:H160_SDK_APCP_CRHT_ON
CR.HT OFF	H:H160_SDK_APCP_CRHT_OFF
CR.HT Clockwise	H:H160_SDK_APCP_CRHT_Clockwise
CR.HT AntiClockwise	H:H160_SDK_APCP_CRHT_AntiClockwise
VS TOGGLE	H:H160_SDK_APCP_VS_TOGGLE
VS ON	H:H160_SDK_APCP_VS_ON
VS OFF	H:H160_SDK_APCP_VS_OFF
VS Clockwise	H:H160_SDK_APCP_VS_Clockwise
VS AntiClockwise	H:H160_SDK_APCP_VS_AntiClockwise
HDG TOGGLE	H:H160_SDK_APCP_HDG_TOGGLE
HDG ON	H:H160_SDK_APCP_HDG_ON
HDG OFF	H:H160_SDK_APCP_HDG_OFF
HDG Clockwise	H:H160_SDK_APCP_HDG_Clockwise
HDG AntiClockwise	H:H160_SDK_APCP_HDG_AntiClockwise
IAS TOGGLE	H:H160_SDK_APCP_IAS_TOGGLE
IAS ON	H:H160_SDK_APCP_IAS_ON
IAS OFF	H:H160_SDK_APCP_IAS_OFF
IAS Clockwise	H:H160_SDK_APCP_IAS_Clockwise
IAS AntiClockwise	H:H160_SDK_APCP_IAS_AntiClockwise
Easy AFCS Toggle	H:H160_SDK_AP_AFCS_EASY_TOGGLE
Easy AFCS On	H:H160_SDK_AP_AFCS_EASY_ON
Easy AFCS Off	H:H160_SDK_AP_AFCS_EASY_OFF

**Cyclic Control**

Name	Event
AP/BKUP ON	H:H160_SDK_AP_APBKUPON_UP
AP/BKUP ON (AP1 Only)	H:H160_SDK_AP_APBKUPON_LEFT
AP/BKUP ON (AP2 Only)	H:H160_SDK_AP_APBKUPON_RIGHT
AP/BKUP CUT	H:H160_SDK_AP_APBKUPCUT
AP/UM OFF	H:H160_SDK_AP_UM_OFF
AP/GTC	H:H160_SDK_AP_GTCGTC

AP/GTC (Direct to GTC.H) (Advanced)	H:H160_SDK_AP_GTCGTCH_HOVER
Cyclic Beep Trim RIGHT	H:H160_SDK_CYCLIC_BEEP_RIGHT
Cyclic Beep Trim LEFT	H:H160_SDK_CYCLIC_BEEP_LEFT
Cyclic Beep Trim UP	H:H160_SDK_CYCLIC_BEEP_UP
Cyclic Beep Trim DOWN	H:H160_SDK_CYCLIC_BEEP_DOWN
Cyclic Beep Trim RESET/Zero (Uncommon)	H:H160_SDK_CYCLIC_BEEP_RESET
Set New Cyclic Center	H:H160_SDK_CYCLIC_FORCE_TRIM_SET_NEW_CENTER
Trim Release (HOLD)	H:H160_SDK_CYCLIC_TRIM_RELEASE_HOLD
Trim Release (Latch: Open)	H:H160_SDK_CYCLIC_TRIM_RELEASE_LATCH_PUSH
Trim Release (Latch: Closed)	H:H160_SDK_CYCLIC_TRIM_RELEASE_LATCH_RELEASE
Trim Release (Latch: Toggle)	H:H160_SDK_CYCLIC_TRIM_RELEASE_LATCH_TOGGLE
Message List RESET	H:H160_SDK_MESSAGELIST_RESET

## Collective Control

Name	Event
Collective Beep Trim RIGHT	H:H160_SDK_COLLECTIVE_BEEP_RIGHT
Collective Beep Trim LEFT	H:H160_SDK_COLLECTIVE_BEEP_LEFT
Collective Beep Trim UP	H:H160_SDK_COLLECTIVE_BEEP_UP
Collective Beep Trim DOWN	H:H160_SDK_COLLECTIVE_BEEP_DOWN
Collective Beep Trim ATT YAW AUTORESET	H:H160_SDK_COLLECTIVE_YAW_TRIM_AUTO_RESET
Collective Beep Release (HOLD)	H:H160_SDK_COLLECTIVE_TRIM_RELEASE_HOLD
Collective Beep Release (Latch: Open)	H:H160_SDK_COLLECTIVE_TRIM_RELEASE_LATCH_PUSH
Collective Beep Release (Latch: Closed)	H:H160_SDK_COLLECTIVE_TRIM_RELEASE_LATCH_RELEASE
OEI HI/LO (Low)	H:H160_SDK_COLLECTIVE_OEI_HILO_LO
OEI HI/LO (High)	H:H160_SDK_COLLECTIVE_OEI_HILO_HI
OEI HI/LO (Toggle)	H:H160_SDK_COLLECTIVE_OEI_HILO_TOGGLE
Fill Floats	H:H160_SDK_FILL_FLOATS
Repack Floats (Sim)	H:H160_SDK_REPACK_FLOATS
GA (Go Around)	H:H160_SDK_COLLECTIVE_GA
Wiper	H:H160_SDK_COLLECTIVE_WIPER_PUSH

## Misc

Name	Event
Primary Action (Primary)	H:H160_SDK_PRIMARY_ACTION_COMMAND
Secondary Action (Secondary)	H:H160_SDK_SECONDARY_ACTION_COMMAND

## Cabin

Name	Event
Cockpit Door Left TOGGLE	H:H160_SDK_DOOR_COCKPIT_L_TOGGLE
Cockpit Door Left OPEN	H:H160_SDK_DOOR_COCKPIT_L_OPEN
Cockpit Door Left CLOSE	H:H160_SDK_DOOR_COCKPIT_L_CLOSE
Cockpit Door Right TOGGLE	H:H160_SDK_DOOR_COCKPIT_R_TOGGLE
Cockpit Door Right OPEN	H:H160_SDK_DOOR_COCKPIT_R_OPEN
Cockpit Door Right CLOSE	H:H160_SDK_DOOR_COCKPIT_R_CLOSE
Pax Door Left TOGGLE	H:H160_SDK_DOOR_PAX_L_TOGGLE
Pax Door Left OPEN	H:H160_SDK_DOOR_PAX_L_OPEN
Pax Door Left CLOSE	H:H160_SDK_DOOR_PAX_L_CLOSE
Pax Door Right TOGGLE	H:H160_SDK_DOOR_PAX_R_TOGGLE
Pax Door Right OPEN	H:H160_SDK_DOOR_PAX_R_OPEN
Pax Door Right CLOSE	H:H160_SDK_DOOR_PAX_R_CLOSE
Cargo Door Left TOGGLE	H:H160_SDK_DOOR_CARGO_L_TOGGLE
Cargo Door Left OPEN	H:H160_SDK_DOOR_CARGO_L_OPEN
Cargo Door Left CLOSE	H:H160_SDK_DOOR_CARGO_L_CLOSE
Cargo Door Right TOGGLE	H:H160_SDK_DOOR_CARGO_R_TOGGLE
Cargo Door Right OPEN	H:H160_SDK_DOOR_CARGO_R_OPEN
Cargo Door Right CLOSE	H:H160_SDK_DOOR_CARGO_R_CLOSE
Pilot TOGGLE	H:H160_SDK_PILOT_CAPT_TOGGLE
Pilot ON	H:H160_SDK_PILOT_CAPT_ON

Pilot OFF	H:H160_SDK_PILOT_CAPT_OFF
Copilot TOGGLE	H:H160_SDK_PILOT_FO_TOGGLE
Copilot ON	H:H160_SDK_PILOT_FO_ON
Copilot OFF	H:H160_SDK_PILOT_FO_OFF
HEMS Stretcher Toggle	H:H160_SDK_HEMS_STRETCHER_TOGGLE
HEMS Stretcher Eject	H:H160_SDK_HEMS_STRETCHER_EJECT
HEMS Stretcher Retract	H:H160_SDK_HEMS_STRETCHER_RETRACT
HEMS Stretcher Removed	H:H160_SDK_HEMS_STRETCHER_REMOVED
HEMS Stretcher Present without patient	H:H160_SDK_HEMS_STRETCHER_NOPATIENT
HEMS Stretcher Present with patient	H:H160_SDK_HEMS_STRETCHER_PATIENT
Pax 1 Toggle	H:H160_SDK_PAX_1_TOGGLE
Pax 1 On	H:H160_SDK_PAX_1_ON
Pax 1 Off	H:H160_SDK_PAX_1_OFF
Pax 2 Toggle	H:H160_SDK_PAX_2_TOGGLE
Pax 2 On	H:H160_SDK_PAX_2_ON
Pax 2 Off	H:H160_SDK_PAX_2_OFF
Pax 3 Toggle	H:H160_SDK_PAX_3_TOGGLE
Pax 3 On	H:H160_SDK_PAX_3_ON
Pax 3 Off	H:H160_SDK_PAX_3_OFF
Pax 4 Toggle	H:H160_SDK_PAX_4_TOGGLE
Pax 4 On	H:H160_SDK_PAX_4_ON
Pax 4 Off	H:H160_SDK_PAX_4_OFF
Pax 5 Toggle	H:H160_SDK_PAX_5_TOGGLE
Pax 5 On	H:H160_SDK_PAX_5_ON
Pax 5 Off	H:H160_SDK_PAX_5_OFF
Pax 6 Toggle	H:H160_SDK_PAX_6_TOGGLE
Pax 6 On	H:H160_SDK_PAX_6_ON
Pax 6 Off	H:H160_SDK_PAX_6_OFF
Pax 7 Toggle	H:H160_SDK_PAX_7_TOGGLE
Pax 7 On	H:H160_SDK_PAX_7_ON
Pax 7 Off	H:H160_SDK_PAX_7_OFF
Pax 8 Toggle	H:H160_SDK_PAX_8_TOGGLE
Pax 8 On	H:H160_SDK_PAX_8_ON
Pax 8 Off	H:H160_SDK_PAX_8_OFF
Pax 9 Toggle	H:H160_SDK_PAX_9_TOGGLE
Pax 9 On	H:H160_SDK_PAX_9_ON
Pax 9 Off	H:H160_SDK_PAX_9_OFF
Pax 10 Toggle	H:H160_SDK_PAX_10_TOGGLE
Pax 10 On	H:H160_SDK_PAX_10_ON
Pax 10 Off	H:H160_SDK_PAX_10_OFF
Pax 11 Toggle	H:H160_SDK_PAX_11_TOGGLE
Pax 11 On	H:H160_SDK_PAX_11_ON
Pax 11 Off	H:H160_SDK_PAX_11_OFF
Pax 12 Toggle	H:H160_SDK_PAX_12_TOGGLE
Pax 12 On	H:H160_SDK_PAX_12_ON
Pax 12 Off	H:H160_SDK_PAX_12_OFF

**Misc**

Name	Event
State Load READY FOR TAKEOFF	H:H160_SDK_MISC_CMD_READYFORTAKEOFF
State Load COLD AND DARK	H:H160_SDK_MISC_CMD_COLDANDDARK
Rotor Brake TOGGLE	H:H160_SDK_ROTOR_BRAKE_TOGGLE
Rotor Brake ON	H:H160_SDK_ROTOR_BRAKE_ON
Rotor Brake OFF	H:H160_SDK_ROTOR_BRAKE_OFF
Nose Wheel Lock ON	H:H160_SDK_NOSE_WHEEL_LOCK_ON
Nose Wheel Lock OFF	H:H160_SDK_NOSE_WHEEL_LOCK_OFF
Nose Wheel Lock TOGGLE	H:H160_SDK_NOSE_WHEEL_LOCK_TOGGLE
Emergency Floats OFF	H:H160_SDK_OH_EMER_FLOATS_OFF
Emergency Floats AUTO	H:H160_SDK_OH_EMER_FLOATS_AUTO

Emergency Floats MANUAL	H:H160_SDK_OH_EMER_FLOATS_MAN
Windshield Wiper OFF	H:H160_SDK_OH_WINDSHIELD_WIPER_OFF
Windshield Wiper SLOW	H:H160_SDK_OH_WINDSHIELD_WIPER_SLOW
Windshield Wiper FAST	H:H160_SDK_OH_WINDSHIELD_WIPER_FAST
FMS1 Source TOGGLE	H:H160_SDK_MISC_FMS1_TOGGLE
FMS1 Source ON	H:H160_SDK_MISC_FMS1_ON
FMS1 Source OFF	H:H160_SDK_MISC_FMS1_OFF
FMS2 Source TOGGLE	H:H160_SDK_MISC_FMS2_TOGGLE
FMS2 Source ON	H:H160_SDK_MISC_FMS2_ON
FMS2 Source OFF	H:H160_SDK_MISC_FMS2_OFF
Master Brightness Increase	H:H160_SDK_MASTERBRIGHTNESS_INC
Master Brightness Decrease	H:H160_SDK_MASTERBRIGHTNESS_DEC
Luxury Divider Wall TOGGLE	H:H160_SDK_LUX_DIVIDER_TOGGLE
Luxury Divider Wall UP	H:H160_SDK_LUX_DIVIDER_UP
Luxury Divider Wall DOWN	H:H160_SDK_LUX_DIVIDER_DOWN
TDSSim GTNXi Nav Source UNIT1	H:H160_SDK_MISC_GTN750_TDSSIM_NAVSOURCE_UNIT_1
TDSSim GTNXi Nav Source UNIT2	H:H160_SDK_MISC_GTN750_TDSSIM_NAVSOURCE_UNIT_2
TDSSim GTNXi Nav Source MSFS	H:H160_SDK_MISC_GTN750_TDSSIM_NAVSOURCE_MSFS
TDSSim GTNXi Nav Source NEXT	H:H160_SDK_MISC_GTN750_TDSSIM_NAVSOURCE_NEXT

### Center Console WXRCP

Name	Event
Weather Radar Power OFF	H:H160_SDK_WXR_OFF
Weather Radar Power STANDBY	H:H160_SDK_WXR_STBY
Weather Radar Power TEST	H:H160_SDK_WXR_TEST
Weather Radar Power ON	H:H160_SDK_WXR_ON
Weather Radar Power Knob UP	H:H160_SDK_WXR_UP
Weather Radar Power Knob NEXT	H:H160_SDK_WXR_UP_LOOP
Weather Radar Power Knob DOWN	H:H160_SDK_WXR_DOWN
Weather Radar Tilt Knob UP	H:H160_SDK_WXR_TILT_UP
Weather Radar Tilt Knob DOWN	H:H160_SDK_WXR_TILT_DOWN

### Tablet

Name	Event
Hinge Open/Close	H:H160_SDK_TABLET_OPENCLOSE
Home (Push)	H:H160_SDK_TABLET_HOME_PUSH
Home (Push Long)	H:H160_SDK_TABLET_HOME_PUSH_LONG
Open Action Center	H:H160_SDK_TABLET_OPEN_ACTIONCENTER
Launch Maps	H:H160_SDK_TABLET_OPENAPP_MAPS
Launch Missions	H:H160_SDK_TABLET_OPENAPP_MISSIONS
Launch Setup	H:H160_SDK_TABLET_OPENAPP_SETUP
Launch Documents	H:H160_SDK_TABLET_OPENAPP_DOCUMENTS
Launch EFBCConnect	H:H160_SDK_TABLET_OPENAPP_WEB_EFBCCONNECT
Launch Web Browser	H:H160_SDK_TABLET_OPENAPP_WEB
Launch METAR	H:H160_SDK_TABLET_OPENAPP_METAR
Launch LittleNavMap	H:H160_SDK_TABLET_OPENAPP_LITTLENAVMAP
Launch Navigraph Charts	H:H160_SDK_TABLET_OPENAPP_NAVIGRAPH
Launch Flappy Bird	H:H160_SDK_TABLET_OPENAPP_FLAPPYBIRD
Launch Alarms & Clock	H:H160_SDK_TABLET_OPENAPP_CLOCK
Launch Activity Log	H:H160_SDK_TABLET_OPENAPP_ACTIVITYLOG
Launch Direction Finder	H:H160_SDK_TABLET_OPENAPP_DF
Launch Neopad	H:H160_SDK_TABLET_OPENAPP_NEOPAD
Map ZOOM IN	H:H160_SDK_TABLET_MAPSAPP_ZOOM_IN
Map ZOOM OUT	H:H160_SDK_TABLET_MAPSAPP_ZOOM_OUT
Map ZOOM Level3	H:H160_SDK_TABLET_MAPSAPP_ZOOM_SET_3
Map ZOOM Level4	H:H160_SDK_TABLET_MAPSAPP_ZOOM_SET_4
Map ZOOM Level5	H:H160_SDK_TABLET_MAPSAPP_ZOOM_SET_5
Map ZOOM Level6	H:H160_SDK_TABLET_MAPSAPP_ZOOM_SET_6

Map ZOOM Level7	H:H160_SDK_TABLET_MAPSAPP_ZOOM_SET_7
Map ZOOM Level8	H:H160_SDK_TABLET_MAPSAPP_ZOOM_SET_8
Map ZOOM Level9	H:H160_SDK_TABLET_MAPSAPP_ZOOM_SET_9
Map ZOOM Level10	H:H160_SDK_TABLET_MAPSAPP_ZOOM_SET_10
Map ZOOM Level11	H:H160_SDK_TABLET_MAPSAPP_ZOOM_SET_11
Map ZOOM Level12	H:H160_SDK_TABLET_MAPSAPP_ZOOM_SET_12
Map ZOOM Level13	H:H160_SDK_TABLET_MAPSAPP_ZOOM_SET_13
Map ZOOM Level14	H:H160_SDK_TABLET_MAPSAPP_ZOOM_SET_14
Map ZOOM Level15	H:H160_SDK_TABLET_MAPSAPP_ZOOM_SET_15
Map ZOOM Level16	H:H160_SDK_TABLET_MAPSAPP_ZOOM_SET_16
Map ZOOM Level17	H:H160_SDK_TABLET_MAPSAPP_ZOOM_SET_17
Map FollowMe TOGGLE	H:H160_SDK_TABLET_MAPSAPP_FOLLOWME_TOGGLE
Map FollowMe ON	H:H160_SDK_TABLET_MAPSAPP_FOLLOWME_ON
Map FollowMe OFF	H:H160_SDK_TABLET_MAPSAPP_FOLLOWME_OFF
Map Orientation TOGGLE	H:H160_SDK_TABLET_MAPSAPP_ORIENTATION_TOGGLE
Map Orientation NorthUP	H:H160_SDK_TABLET_MAPSAPP_ORIENTATION_NORTHUP
Map Orientation HeadingUP	H:H160_SDK_TABLET_MAPSAPP_ORIENTATION_HEADINGUP
Map DB Layer Hospital Helipad ON	H:H160_SDK_TABLET_MAPSAPP_SET_DB_LAYER_ON_H_HOSPITAL
Map DB Layer Civil Helipad ON	H:H160_SDK_TABLET_MAPSAPP_SET_DB_LAYER_ON_H_CIVIL
Map DB Layer Airport Primary ON	H:H160_SDK_TABLET_MAPSAPP_SET_DB_LAYER_ON_AIRPORT
Map DB Layer Hospital Helipad OFF	H:H160_SDK_TABLET_MAPSAPP_SET_DB_LAYER_OFF_H_HOSPITAL
Map DB Layer Civil Helipad OFF	H:H160_SDK_TABLET_MAPSAPP_SET_DB_LAYER_OFF_H_CIVIL
Map DB Layer Airport Primary OFF	H:H160_SDK_TABLET_MAPSAPP_SET_DB_LAYER_OFF_AIRPORT
Map DB Layer Hospital Helipad TOGGLE	H:H160_SDK_TABLET_MAPSAPP_SET_DB_LAYER_TOGGLE_H_HOSPITAL
Map DB Layer Civil Helipad TOGGLE	H:H160_SDK_TABLET_MAPSAPP_SET_DB_LAYER_TOGGLE_H_CIVIL
Map DB Layer Airport Primary TOGGLE	H:H160_SDK_TABLET_MAPSAPP_SET_DB_LAYER_TOGGLE_AIRPORT

## Hype Radio App

Name	Event
Connect_Reconnect_SyncLocation	H:H160_SDK_HYPERADIO_CONNECT
Volume Down	H:H160_SDK_HYPERADIO_VOLUME_DOWN
Volume Up	H:H160_SDK_HYPERADIO_VOLUME_UP
Stop	H:H160_SDK_HYPERADIO_STOP
Select Previous Station	H:H160_SDK_HYPERADIO_STATION_PREV
Select Next Station	H:H160_SDK_HYPERADIO_STATION_NEXT
Select Station 1	H:H160_SDK_HYPERADIO_STATION_1
Select Station 2	H:H160_SDK_HYPERADIO_STATION_2
Select Station 3	H:H160_SDK_HYPERADIO_STATION_3
Select Station 4	H:H160_SDK_HYPERADIO_STATION_4
Select Station 5	H:H160_SDK_HYPERADIO_STATION_5
Select Station 6	H:H160_SDK_HYPERADIO_STATION_6
Select Station 7	H:H160_SDK_HYPERADIO_STATION_7
Select Station 8	H:H160_SDK_HYPERADIO_STATION_8
Select Station 9	H:H160_SDK_HYPERADIO_STATION_9
Select Station 10	H:H160_SDK_HYPERADIO_STATION_10
Select Station 11	H:H160_SDK_HYPERADIO_STATION_11
Select Station 12	H:H160_SDK_HYPERADIO_STATION_12
Select Station 13	H:H160_SDK_HYPERADIO_STATION_13
Select Station 14	H:H160_SDK_HYPERADIO_STATION_14
Select Station 15	H:H160_SDK_HYPERADIO_STATION_15

## Tablet

Name	Event
Mission Command 1 PRESS	H:H160_SDK_MISSION_ACTION_COMMAND_1
Mission Command 2 PRESS	H:H160_SDK_MISSION_ACTION_COMMAND_2
Mission Command 3 PRESS	H:H160_SDK_MISSION_ACTION_COMMAND_3
Mission Command 4 PRESS	H:H160_SDK_MISSION_ACTION_COMMAND_4
Mission Command 5 PRESS	H:H160_SDK_MISSION_ACTION_COMMAND_5

Mission Command 6 PRESS

H:H160\_SDK\_MISSION\_ACTION\_COMMAND\_6

## Equipment Setup

Name	Event
WSPS Top TOGGLE	H:H160_SDK_EQUIP_WSPS_TOP_TOGGLE
WSPS Top ON	H:H160_SDK_EQUIP_WSPS_TOP_ON
WSPS Top OFF	H:H160_SDK_EQUIP_WSPS_TOP_OFF

## MFDs

Name	Event
MFD1 SoftKey Top 1	H:MFD1_SoftKey_T1
MFD1 SoftKey Top 2	H:MFD1_SoftKey_T2
MFD1 SoftKey Top 3	H:MFD1_SoftKey_T3
MFD1 SoftKey Top 4	H:MFD1_SoftKey_T4
MFD1 SoftKey Top 5	H:MFD1_SoftKey_T5
MFD1 SoftKey Top 6	H:MFD1_SoftKey_T6
MFD1 SoftKey Left 1	H:MFD1_SoftKey_L1
MFD1 SoftKey Left 2	H:MFD1_SoftKey_L2
MFD1 SoftKey Left 3	H:MFD1_SoftKey_L3
MFD1 SoftKey Left 4	H:MFD1_SoftKey_L4
MFD1 SoftKey Left 5	H:MFD1_SoftKey_L5
MFD1 SoftKey Left 6	H:MFD1_SoftKey_L6
MFD1 SoftKey Right 1	H:MFD1_SoftKey_R1
MFD1 SoftKey Right 2	H:MFD1_SoftKey_R2
MFD1 SoftKey Right 3	H:MFD1_SoftKey_R3
MFD1 SoftKey Right 4	H:MFD1_SoftKey_R4
MFD1 SoftKey Right 5	H:MFD1_SoftKey_R5
MFD1 SoftKey Right 6	H:MFD1_SoftKey_R6
MFD1 SoftKey Bottom 1	H:MFD1_SoftKey_B1
MFD1 SoftKey Bottom 2	H:MFD1_SoftKey_B2
MFD1 SoftKey Bottom 3	H:MFD1_SoftKey_B3
MFD1 SoftKey Bottom 4	H:MFD1_SoftKey_B4
MFD1 SoftKey Bottom 5	H:MFD1_SoftKey_B5
MFD1 SoftKey Bottom 6	H:MFD1_SoftKey_B6
MFD1 Small Knob Clockwise	H:MFD1_SoftKey_KnobInnerClockwise
MFD1 Small Knob AntiClockwise	H:MFD1_SoftKey_KnobInnerAntiClockwise
MFD1 Small Knob Push	H:MFD1_SoftKey_KnobInnerPush
MFD1 Small Knob Push (Long)	H:MFD1_SoftKey_KnobInnerPushLong
MFD1 Large Knob Clockwise	H:MFD1_SoftKey_KnobOuterClockwise
MFD1 Large Knob AntiClockwise	H:MFD1_SoftKey_KnobOuterAntiClockwise
MFD1 LUM (oveall intensity) Up	H:MFD1_SoftKey_LUM_UP
MFD1 LUM (oveall intensity) Down	H:MFD1_SoftKey_LUM_DOWN
MFD1 BRT (underlay intensity) Up	H:MFD1_SoftKey_BRT_UP
MFD1 BRT (underlay intensity) Down	H:MFD1_SoftKey_BRT_DOWN
MFD1 CTRS (overlay intensity) Up	H:MFD1_SoftKey_CTRS_UP
MFD1 CTRS (overlay intensity) Down	H:MFD1_SoftKey_CTRSW_DOWN
MFD1 Power	H:MFD1_SoftKey_POWER
MFD2 SoftKey Top 1	H:MFD2_SoftKey_T1
MFD2 SoftKey Top 2	H:MFD2_SoftKey_T2
MFD2 SoftKey Top 3	H:MFD2_SoftKey_T3
MFD2 SoftKey Top 4	H:MFD2_SoftKey_T4
MFD2 SoftKey Top 5	H:MFD2_SoftKey_T5
MFD2 SoftKey Top 6	H:MFD2_SoftKey_T6
MFD2 SoftKey Left 1	H:MFD2_SoftKey_L1
MFD2 SoftKey Left 2	H:MFD2_SoftKey_L2
MFD2 SoftKey Left 3	H:MFD2_SoftKey_L3
MFD2 SoftKey Left 4	H:MFD2_SoftKey_L4
MFD2 SoftKey Left 5	H:MFD2_SoftKey_L5

MFD2 SoftKey Left 6	H:MFD2_SoftKey_L6
MFD2 SoftKey Right 1	H:MFD2_SoftKey_R1
MFD2 SoftKey Right 2	H:MFD2_SoftKey_R2
MFD2 SoftKey Right 3	H:MFD2_SoftKey_R3
MFD2 SoftKey Right 4	H:MFD2_SoftKey_R4
MFD2 SoftKey Right 5	H:MFD2_SoftKey_R5
MFD2 SoftKey Right 6	H:MFD2_SoftKey_R6
MFD2 SoftKey Bottom 1	H:MFD2_SoftKey_B1
MFD2 SoftKey Bottom 2	H:MFD2_SoftKey_B2
MFD2 SoftKey Bottom 3	H:MFD2_SoftKey_B3
MFD2 SoftKey Bottom 4	H:MFD2_SoftKey_B4
MFD2 SoftKey Bottom 5	H:MFD2_SoftKey_B5
MFD2 SoftKey Bottom 6	H:MFD2_SoftKey_B6
MFD2 Small Knob Clockwise	H:MFD2_SoftKey_KnobInnerClockwise
MFD2 Small Knob AntiClockwise	H:MFD2_SoftKey_KnobInnerAntiClockwise
MFD2 Small Knob Push	H:MFD2_SoftKey_KnobInnerPush
MFD2 Small Knob Push (Long)	H:MFD2_SoftKey_KnobInnerPushLong
MFD2 Large Knob Clockwise	H:MFD2_SoftKey_KnobOuterClockwise
MFD2 Large Knob AntiClockwise	H:MFD2_SoftKey_KnobOuterAntiClockwise
MFD2 LUM (oveall intensity) Up	H:MFD2_SoftKey_LUM_UP
MFD2 LUM (oveall intensity) Down	H:MFD2_SoftKey_LUM_DOWN
MFD2 BRT (underlay intensity) Up	H:MFD2_SoftKey_BRT_UP
MFD2 BRT (underlay intensity) Down	H:MFD2_SoftKey_BRT_DOWN
MFD2 CTRS (overlay intensity) Up	H:MFD2_SoftKey_CTRS_UP
MFD2 CTRS (overlay intensity) Down	H:MFD2_SoftKey_CTRSW_DOWN
MFD2 Power	H:MFD2_SoftKey_POWER
MFD2 Set Nav Source NAV1	H:H160_SDK_MFD2_NAV_SRC_SET_1
MFD2 Set Nav Source NAV2	H:H160_SDK_MFD2_NAV_SRC_SET_2
MFD2 Set Nav Source GPS	H:H160_SDK_MFD2_NAV_SRC_SET_3
MFD3 SoftKey Top 1	H:MFD3_SoftKey_T1
MFD3 SoftKey Top 2	H:MFD3_SoftKey_T2
MFD3 SoftKey Top 3	H:MFD3_SoftKey_T3
MFD3 SoftKey Top 4	H:MFD3_SoftKey_T4
MFD3 SoftKey Top 5	H:MFD3_SoftKey_T5
MFD3 SoftKey Top 6	H:MFD3_SoftKey_T6
MFD3 SoftKey Left 1	H:MFD3_SoftKey_L1
MFD3 SoftKey Left 2	H:MFD3_SoftKey_L2
MFD3 SoftKey Left 3	H:MFD3_SoftKey_L3
MFD3 SoftKey Left 4	H:MFD3_SoftKey_L4
MFD3 SoftKey Left 5	H:MFD3_SoftKey_L5
MFD3 SoftKey Left 6	H:MFD3_SoftKey_L6
MFD3 SoftKey Right 1	H:MFD3_SoftKey_R1
MFD3 SoftKey Right 2	H:MFD3_SoftKey_R2
MFD3 SoftKey Right 3	H:MFD3_SoftKey_R3
MFD3 SoftKey Right 4	H:MFD3_SoftKey_R4
MFD3 SoftKey Right 5	H:MFD3_SoftKey_R5
MFD3 SoftKey Right 6	H:MFD3_SoftKey_R6
MFD3 SoftKey Bottom 1	H:MFD3_SoftKey_B1
MFD3 SoftKey Bottom 2	H:MFD3_SoftKey_B2
MFD3 SoftKey Bottom 3	H:MFD3_SoftKey_B3
MFD3 SoftKey Bottom 4	H:MFD3_SoftKey_B4
MFD3 SoftKey Bottom 5	H:MFD3_SoftKey_B5
MFD3 SoftKey Bottom 6	H:MFD3_SoftKey_B6
MFD3 Small Knob Clockwise	H:MFD3_SoftKey_KnobInnerClockwise
MFD3 Small Knob AntiClockwise	H:MFD3_SoftKey_KnobInnerAntiClockwise
MFD3 Small Knob Push	H:MFD3_SoftKey_KnobInnerPush
MFD3 Small Knob Push (Long)	H:MFD3_SoftKey_KnobInnerPushLong
MFD3 Large Knob Clockwise	H:MFD3_SoftKey_KnobOuterClockwise
MFD3 Large Knob AntiClockwise	H:MFD3_SoftKey_KnobOuterAntiClockwise

MFD3 LUM (oveall intensity) Up	H:MFD3_SoftKey_LUM_UP
MFD3 LUM (oveall intensity) Down	H:MFD3_SoftKey_LUM_DOWN
MFD3 BRT (underlay intensity) Up	H:MFD3_SoftKey_BRT_UP
MFD3 BRT (underlay intensity) Down	H:MFD3_SoftKey_BRT_DOWN
MFD3 CTRS (overlay intensity) Up	H:MFD3_SoftKey_CTRS_UP
MFD3 CTRS (overlay intensity) Down	H:MFD3_SoftKey_CTRSW_DOWN
MFD3 Power	H:MFD3_SoftKey_POWER
MFD4 SoftKey Top 1	H:MFD4_SoftKey_T1
MFD4 SoftKey Top 2	H:MFD4_SoftKey_T2
MFD4 SoftKey Top 3	H:MFD4_SoftKey_T3
MFD4 SoftKey Top 4	H:MFD4_SoftKey_T4
MFD4 SoftKey Top 5	H:MFD4_SoftKey_T5
MFD4 SoftKey Top 6	H:MFD4_SoftKey_T6
MFD4 SoftKey Left 1	H:MFD4_SoftKey_L1
MFD4 SoftKey Left 2	H:MFD4_SoftKey_L2
MFD4 SoftKey Left 3	H:MFD4_SoftKey_L3
MFD4 SoftKey Left 4	H:MFD4_SoftKey_L4
MFD4 SoftKey Left 5	H:MFD4_SoftKey_L5
MFD4 SoftKey Left 6	H:MFD4_SoftKey_L6
MFD4 SoftKey Right 1	H:MFD4_SoftKey_R1
MFD4 SoftKey Right 2	H:MFD4_SoftKey_R2
MFD4 SoftKey Right 3	H:MFD4_SoftKey_R3
MFD4 SoftKey Right 4	H:MFD4_SoftKey_R4
MFD4 SoftKey Right 5	H:MFD4_SoftKey_R5
MFD4 SoftKey Right 6	H:MFD4_SoftKey_R6
MFD4 SoftKey Bottom 1	H:MFD4_SoftKey_B1
MFD4 SoftKey Bottom 2	H:MFD4_SoftKey_B2
MFD4 SoftKey Bottom 3	H:MFD4_SoftKey_B3
MFD4 SoftKey Bottom 4	H:MFD4_SoftKey_B4
MFD4 SoftKey Bottom 5	H:MFD4_SoftKey_B5
MFD4 SoftKey Bottom 6	H:MFD4_SoftKey_B6
MFD4 Small Knob Clockwise	H:MFD4_SoftKey_KnobInnerClockwise
MFD4 Small Knob AntiClockwise	H:MFD4_SoftKey_KnobInnerAntiClockwise
MFD4 Small Knob Push	H:MFD4_SoftKey_KnobInnerPush
MFD4 Small Knob Push (Long)	H:MFD4_SoftKey_KnobInnerPushLong
MFD4 Large Knob Clockwise	H:MFD4_SoftKey_KnobOuterClockwise
MFD4 Large Knob AntiClockwise	H:MFD4_SoftKey_KnobOuterAntiClockwise
MFD4 LUM (oveall intensity) Up	H:MFD4_SoftKey_LUM_UP
MFD4 LUM (oveall intensity) Down	H:MFD4_SoftKey_LUM_DOWN
MFD4 BRT (underlay intensity) Up	H:MFD4_SoftKey_BRT_UP
MFD4 BRT (underlay intensity) Down	H:MFD4_SoftKey_BRT_DOWN
MFD4 CTRS (overlay intensity) Up	H:MFD4_SoftKey_CTRS_UP
MFD4 CTRS (overlay intensity) Down	H:MFD4_SoftKey_CTRSW_DOWN
MFD4 Power	H:MFD4_SoftKey_POWER

**IESI**

Name	Event
Baro Knob Clockwise	H:H160_SDK_IESI_BARO_CLOCKWISE
Baro Knob AntiClockwise	H:H160_SDK_IESI_BARO_ANTICLOCKWISE
Baro STD	H:H160_SDK_IESI_BARO_STD
Cage	H:H160_SDK_IESI_CAGE
Brightness Up	H:H160_SDK_IESI_BRT_UP
Brightness Down	H:H160_SDK_IESI_BRT_DOWN

**Center Console Other**

Name	Event
ELTCP ELT ON	H:H160_SDK_ELT_SWITCH_ON
ELTCP ELT ARM	H:H160_SDK_ELT_SWITCH_ARM

ELTCP ELT RESET	H:H160_SDK_ELT_SWITCH_RESET
ANTICOL Light OFF	H:H160_SDK_INT_LIGHT_ANTICOL_OFF
ANTICOL Light RED	H:H160_SDK_INT_LIGHT_ANTICOL_RED
ANTICOL Light WHITE	H:H160_SDK_INT_LIGHT_ANTICOL_WHITE
ANTICOL Light INC	H:H160_SDK_INT_LIGHT_ANTICOL_INC
ANTICOL Light DEC	H:H160_SDK_INT_LIGHT_ANTICOL_DEC
PARKING BRAKE OFF	H:H160_SDK_PARKING_BRAKE_OFF
PARKING BRAKE ON	H:H160_SDK_PARKING_BRAKE_ON
PARKING BRAKE TOGGLE	H:H160_SDK_PARKING_BRAKE_TOGGLE

### Sensor Pod

Name	Event
Power TOGGLE	H:H160_SDK_SENSORPOD_MONITOR_POWER_TOGGLE
Power ON	H:H160_SDK_SENSORPOD_MONITOR_POWER_ON
Power OFF	H:H160_SDK_SENSORPOD_MONITOR_POWER_OFF
Move RIGHT	H:H160_SDK_SENSORPOD_MOVE_RIGHT
Move LEFT	H:H160_SDK_SENSORPOD_MOVE_LEFT
Move FORWARD	H:H160_SDK_SENSORPOD_MOVE_FWD
Move AFT	H:H160_SDK_SENSORPOD_MOVE_AFT

### GTN750\_1 Bezel

Name	Event
Home Push	H:GTN750_HomePush
Home Push_Long	H:GTN750_HomePushLong
DirectTo Push	H:GTN750_DirectToPush
Knob Small Increment	H:GTN750_KnobSmallInc
Knob Small Decrement	H:GTN750_KnobSmallDec
Knob Large Increment	H:GTN750_KnobLargeInc
Knob Large Decrement	H:GTN750_KnobLargeDec
Knob Push	H:GTN750_KnobPush
Knob Push_Long	H:GTN750_KnobPushLong
Volume Increment	H:GTN750_VolInc
Volume Decrement	H:GTN750_VolDec
Volume Push	H:GTN750_VolPush

### GTN750\_2 Bezel

Name	Event
Home Push	H:GTN750_2_HomePush
Home Push_Long	H:GTN750_2_HomePushLong
DirectTo Push	H:GTN750_2_DirectToPush
Knob Small Increment	H:GTN750_2_KnobSmallInc
Knob Small Decrement	H:GTN750_2_KnobSmallDec
Knob Large Increment	H:GTN750_2_KnobLargeInc
Knob Large Decrement	H:GTN750_2_KnobLargeDec
Knob Push	H:GTN750_2_KnobPush
Knob Push_Long	H:GTN750_2_KnobPushLong
Volume Increment	H:GTN750_2_VolInc
Volume Decrement	H:GTN750_2_VolDec
Volume Push	H:GTN750_2_VolPush

### CMA9000 FMS\_1

Name	Event
Select R1	H:FMS1_LSK_R1
Select L1	H:FMS1_LSK_L1
Select R2	H:FMS1_LSK_R2
Select L2	H:FMS1_LSK_L2
Select R3	H:FMS1_LSK_R3

Select L3	H:FMS1_LSK_L3
Select R4	H:FMS1_LSK_R4
Select L4	H:FMS1_LSK_L4
Select R5	H:FMS1_LSK_R5
Select L5	H:FMS1_LSK_L5
Select R6	H:FMS1_LSK_R6
Select L6	H:FMS1_LSK_L6
1	H:FMS1_1
2	H:FMS1_2
3	H:FMS1_3
4	H:FMS1_4
5	H:FMS1_5
6	H:FMS1_6
7	H:FMS1_7
8	H:FMS1_8
9	H:FMS1_9
0	H:FMS1_0
A	H:FMS1_A
B	H:FMS1_B
C	H:FMS1_C
D	H:FMS1_D
E	H:FMS1_E
F	H:FMS1_F
G	H:FMS1_G
H	H:FMS1_H
I	H:FMS1_I
J	H:FMS1_J
K	H:FMS1_K
L	H:FMS1_L
M	H:FMS1_M
N	H:FMS1_N
O	H:FMS1_O
P	H:FMS1_P
Q	H:FMS1_Q
R	H:FMS1_R
S	H:FMS1_S
T	H:FMS1_T
U	H:FMS1_U
V	H:FMS1_V
W	H:FMS1_W
X	H:FMS1_X
Y	H:FMS1_Y
Z	H:FMS1_Z
SLASH	H:FMS1_SLASH
SP	H:FMS1_SP
MENU	H:FMS1_MENU
PREV	H:FMS1_PREV
NEXT	H:FMS1_NEXT
PROG	H:FMS1_PROG
LEGS	H:FMS1_LEGS
EXEC	H:FMS1_EXEC
RADIO	H:FMS1_RADIO
FUEL	H:FMS1_FUEL
MARK	H:FMS1_MARK
HOLD	H:FMS1_HOLD
FIX	H:FMS1_FIX
BRT	H:FMS1_BRT
DOT	H:FMS1_DOT
PLUS_MINUS	H:FMS1_PLUS_MINUS

CLR	H:FMS1_CLR
INIT_REF	H:FMS1_INIT_REF
RTE	H:FMS1_RTE
DEP_ARR	H:FMS1_DEP_ARR

**CMA9000 FMS\_2**

<b>Name</b>	<b>Event</b>
Select R1	H:FMS2_LSK_R1
Select L1	H:FMS2_LSK_L1
Select R2	H:FMS2_LSK_R2
Select L2	H:FMS2_LSK_L2
Select R3	H:FMS2_LSK_R3
Select L3	H:FMS2_LSK_L3
Select R4	H:FMS2_LSK_R4
Select L4	H:FMS2_LSK_L4
Select R5	H:FMS2_LSK_R5
Select L5	H:FMS2_LSK_L5
Select R6	H:FMS2_LSK_R6
Select L6	H:FMS2_LSK_L6
1	H:FMS2_1
2	H:FMS2_2
3	H:FMS2_3
4	H:FMS2_4
5	H:FMS2_5
6	H:FMS2_6
7	H:FMS2_7
8	H:FMS2_8
9	H:FMS2_9
0	H:FMS2_0
A	H:FMS2_A
B	H:FMS2_B
C	H:FMS2_C
D	H:FMS2_D
E	H:FMS2_E
F	H:FMS2_F
G	H:FMS2_G
H	H:FMS2_H
I	H:FMS2_I
J	H:FMS2_J
K	H:FMS2_K
L	H:FMS2_L
M	H:FMS2_M
N	H:FMS2_N
O	H:FMS2_O
P	H:FMS2_P
Q	H:FMS2_Q
R	H:FMS2_R
S	H:FMS2_S
T	H:FMS2_T
U	H:FMS2_U
V	H:FMS2_V
W	H:FMS2_W
X	H:FMS2_X
Y	H:FMS2_Y
Z	H:FMS2_Z
SLASH	H:FMS2_SLASH
SP	H:FMS2_SP
MENU	H:FMS2_MENU
PREV	H:FMS2_PREV

NEXT	H:FMS2_NEXT
PROG	H:FMS2_PROG
LEGS	H:FMS2_LEGS
EXEC	H:FMS2_EXEC
RADIO	H:FMS2_RADIO
FUEL	H:FMS2_FUEL
MARK	H:FMS2_MARK
HOLD	H:FMS2_HOLD
FIX	H:FMS2_FIX
BRT	H:FMS2_BRT
DOT	H:FMS2_DOT
PLUS_MINUS	H:FMS2_PLUS_MINUS
CLR	H:FMS2_CLR
INIT_REF	H:FMS2_INIT_REF
RTE	H:FMS2_RTE
DEP_ARR	H:FMS2_DEP_ARR

### CARLS Tactical Radio

Name	Event
Press UP	H:H160_SDK_CARLS_UP
Press DOWN	H:H160_SDK_CARLS_DOWN
Press LEFT	H:H160_SDK_CARLS_LEFT
Press RIGHT	H:H160_SDK_CARLS_RIGHT
Press L1	H:H160_SDK_CARLS_L1
Press L2	H:H160_SDK_CARLS_L2
Press L3	H:H160_SDK_CARLS_L3
Press R1	H:H160_SDK_CARLS_R1
Press R2	H:H160_SDK_CARLS_R2
Press R3	H:H160_SDK_CARLS_R3
Press STAR	H:H160_SDK_CARLS_STAR
Press SHARP	H:H160_SDK_CARLS_SHARP
Press PICK	H:H160_SDK_CARLS_PICK
Press HANG	H:H160_SDK_CARLS_HANG
Press WARNING	H:H160_SDK_CARLS_WARNING
Press 0	H:H160_SDK_CARLS_0
Press 1	H:H160_SDK_CARLS_1
Press 2	H:H160_SDK_CARLS_2
Press 3	H:H160_SDK_CARLS_3
Press 4	H:H160_SDK_CARLS_4
Press 5	H:H160_SDK_CARLS_5
Press 6	H:H160_SDK_CARLS_6
Press 7	H:H160_SDK_CARLS_7
Press 8	H:H160_SDK_CARLS_8
Press 9	H:H160_SDK_CARLS_9

### Enviromental Control (ECS)

Name	Event
Temperature Decrease	H:H160_SDK_ECS_TEMP_DEC
Temperature Increase	H:H160_SDK_ECS_TEMP_INC
Vent Decrease	H:H160_SDK_ECS_VENT_DEC
Vent Increase	H:H160_SDK_ECS_VENT_INC
MASTER INC	H:H160_SDK_ECS_MASTER_INC
MASTER DEC	H:H160_SDK_ECS_MASTER_DEC
MASTER OFF	H:H160_SDK_ECS_MASTER_OFF
MASTER COCKPIT	H:H160_SDK_ECS_MASTER_COCKPIT
MASTER CABIN	H:H160_SDK_ECS_MASTER_CABIN
DEMIST OFF	H:H160_SDK_ECS_DEMIST_OFF
DEMIST ON	H:H160_SDK_ECS_DEMIST_ON

DEMIST TOGGLE	H:H160_SDK_ECS_DEMIST_TOGGLE
AUTO OFF	H:H160_SDK_ECS_AUTO_OFF
AUTO ON	H:H160_SDK_ECS_AUTO_ON
AUTO TOGGLE	H:H160_SDK_ECS_AUTO_TOGGLE
DISTRIBUTION DOWN	H:H160_SDK_ECS_DISTRIBUTION_DOWN
DISTRIBUTION UP	H:H160_SDK_ECS_DISTRIBUTION_UP
DISTRIBUTION TOGGLE	H:H160_SDK_ECS_DISTRIBUTION_TOGGLE
RECIRC OFF	H:H160_SDK_ECS_RECIRC_OFF
RECIRC ON	H:H160_SDK_ECS_RECIRC_ON
RECIRC TOGGLE	H:H160_SDK_ECS_RECIRC_TOGGLE

## Troubleshooting

### I can't find my license key

You can recover your information in these ways:

- You may request your details [be re-sent to your email](#)
- You also should find your info in your account after logging in at [Hype Performance Group Store](#)

### MFD screens are black or the tablet won't open

This almost always means the installation is corrupt or there is an addon conflict.

Resolution:

1. In Hype Operations Center, select [Removes All Packages](#).
2. Select [Install](#) on the latest version of the product.
3. If the aircraft is still not working, **remove all other addons from Community folder.**

### GTN750 screens are black

If the GTN750 screens are black then use the tablet to ensure the setting is as desired. Make sure to remove old H160 packages which enabled GTN750 options, as this setting is now built-in.

Resolution:

1. [H160 Tablet](#) -> [Aircraft](#) (app) -> [Options](#) (page). Change [GTN750 Software](#) to either [pms50](#) or [TDSSim](#).
2. If the GTN750 remains blank, reinstall the vendor software module and try again.
3. If the GTN750 remains black, **remove all other addons from Community folder.**

### It feels like I am fighting the aircraft when I fly.

You need to use [Cyclic Trim Release](#), this removes the deadzone and also pauses the AFCS so it will not compete with you.

### The aircraft is not reliable when flying with autopilot upper modes (HDG, IAS, ALT)

Ensure that your [Cyclic Deadzone](#) is large enough. You must not have accidental HANDS ON input as this will compromise the autopilot.

### Click-spots in the virtual cockpit are offset

Lens Correct will distort the view and break clicking on controls.

Resolution:

1. Turn off the MSFS [Lens Correction](#) setting.

### The camera moves in an erratic way, mostly when taking off and landing.

Something is wrong with the [Camera Shake](#) setting, it needs to be cycled to fix it.

Resolution:

1. Turn On MSFS [Camera Shake](#). Apply.
2. Turn Off MSFS [Camera Shake](#). Apply.

### I have bound a hotkey but it always sends multiple commands

MSFS Bindings have the option for "On Press" and "On Release". By default, keys will repeat after some short delay.

Resolution:

1. Go into MSFS Control settings and change the binding to **On Release**.

### Aircraft has pink textures

- A. A common problem is to install only the [Action Pack](#). You must also install the [H160 Base Pack](#).
- B. Very old civil variant liveries need a [texture.cfg](#) update since they were not authored with one initially:

```
[fltsim]
fallback.1=..\..\hpg-airbus-h160-civ\texture
fallback.2=..\..\hpg-airbus-h160\texture
```

- C. If you are a livery author, check the user guide for [texture.cfg](#) configuration for the variant you are painting.

## MGB Over limit / Aircraft won't takeoff

These warnings indicate aircraft damage. This our new detailed damage model in action.

1. On the tablet, use the [Failures & Maintenance](#) app , and clear the damage by clicking [Do All Maintenance](#) .
2. (optional) turn [Aircraft Damage](#) to OFF in the [Aircraft](#) app on the [Setup](#) page.

## Unable to start at MSFS Helipads

Liveries authored before Sim Update 11 (Nov 2022) will need to be updated in order to avoid preventing H160 from starting at helipads.

Resolution:

1. Locate the [aircraft.cfg](#) file within the livery package (if you find two, update both)
2. Change [ui\\_typerole="Helicopter"](#) to [ui\\_typerole="Rotorcraft"](#) .

The built-in H160 liveries are up to date, as of build 360. If you are still using Version 1.0, you would also need to make this change to the base liveries.

## Problems with WU/SU update

Each time there is a WU or SU update (yes, that is redundant...) and there are H160 loading and/or startup glitches, it's almost always an add-on conflict, an initialization error during load-in, or a msfs binding hiccup. Especially when your H160 has been flying just fine prior. If you experience this, please take a breath before jumping headlong into uninstall, reinstall, reinstall the sim, reinstall Windows, or throw your computer out a Window. 9 times out of 10, a simple restart of the flight brings everything to life, and barring that, a restart of the sim usually solves the easy stuff. After that, suspect add-on conflict, FS20 assets like sceneries and 4th-party liveries, and known culprits like GSX, Flow, and other add-ons that can compete for your bits-and-bytes.

(thx to @FireHawk)

## Known Issues

### WTT Mode is inoperative with helicopters in MSFS

Due to a bug, we are unable to provide a WTT package for H160.

### FSRealistic Low-altitude turbulence is not compatible with helicopters.

FSRealistic software has a mode `Low-altitude turbulence` that will cause problems with the flight model. Turn it off.

### Tablet Time option is off by 1 hour

Reading the time is often wrong due to the [sim DST database being out of date](#) .

### Helicopters don't spawn correctly on some helipads

The position of the helicopter may be forward or aft of the correct position. [Asobo knows about the problem](#)

### Helicopter ground effect transition is abrupt when approaching elevated helipads

[Asobo has confirmed the bug](#) and indicated a fix will come in a future version of MSFS.

### FS 2024: No fuel when start on runway or helipad

You must get fuel via Tablet

### FS 2024: **\*\*Pause\*\*** (ESC) break collective

Don't press ESC when in the air. If you did, you can try to hit F1, this sometimes help. Better to go to the ground and press ESC there.

### FS 2024: Starting cold&dark and stand in front of the helicopter

Press Shift+C to get into the cockpit. Press it again and you can leave it to walk around (ASDW).

### FS 2024: TDS GTNXi is currently blocked

Asobo has confirmed that the developer has what they need to resolve this soon.

## Acronym List

Acronym	Meaning
AAM	Aircraft Maintenance Manual
ACAS	Airborne Collision Avoidance System
ACOL (ACL)	Anti-collision light
ADC	Air data computer
ADELTA	Automatic deployable Emergency Locator Transmitter
ADEP	Aerodrome Of Departure
ADES	Aerodrome Of Destination
ADF	Automatic direction finder
ADI	Attitude Direction Indicator
AEO	All engines operating
AFCS	Automatic Flight Control System
AGL	Above ground level
AHRS	Attitude Heading Reference System
AIL	Aileron
ALT	Altitude or Altitude hold
ALTA	Altitude acquire
ALTM	Altimeter
AMC	Aircraft Management Computer
AMM	Aircraft Maintenance Manual
AOM	Aircraft Operating Manual
APCP	Autopilot control panel
APU	Auiliary Power Unit
ATC	Air Traffic Control
A.TRIM	Automatic trim system
ATT	Attitude or Long term attitude hold
BAT	Battery
BKUP	Backup SAS
BOT	Bottle
CDU	Central Display Unit
CRHT, CR.HT	Cruise height
DA	Decision Altitude
DEG, DEGR	Degraded
DG	Directional gyro
DH	Decision height
DISCH	Discharge
DISCON	Disconnected
DMAP	Digital Map System
DME	Distance measuring equipment
DSAS	Digital SAS
DST	Distance
DTD	Data Transfer Device
DTK	Desired Track
EFB	Electronic Flight Bag
ELT	Emergency Locator Transmitter
EMER	Emergency
EMS	Emergency Medical Services
EPU	External power unit
FADEC	Full Authority Digital Engine Control
FDS	Flight Display System
FLI	First limit indicator
FMS	Flight management system
FND	Flight and Navigation Display
FPA	Flight Path Angle
GA	Go Around
GEN	Generator
GPS	Global positioning system
GS	Ground speed
GTC	Ground trajectory control
GTC.H	Ground trajectory control with hover mode
GTN	GARMIN GTN 750
HAT	Height Above Terrain
HDG	Heading
HEMS	Helicopter Emergency Medical Services
HIGE	Hover in ground effect
HISL	High Intensity Search Light
HLC	High Load Consumer
HMD	Helmet Mounted Display
HOGE	Hover out of ground effect
HPC	High Power Consumer

HTAWS	Helicopter Terrain Awareness and Warning System
IAS	Indicated airspeed
IBF	Inlet Barrier Filter
IESI	Integrated Electronic Standby Instrument/Indicator
IFR	Instrument Flight Rules
IMA	Integrated Modular Avionics
KIAS	Knots Indicated Air Speed
LAVCS	Light Helicopter Active Vibration Control System
LDG	Landing (Landing Light)
LNAV	Lateral Navigation approach (nonprecision)
LNAV+V	Non-precision LNAV approach with vertical guidance
LNAV/VNAV	Lateral Navigation and Vertical Navigation approach
LOC	Localizer
LOW ALT	Low altitude
LP	Localizer Performance without vertical guidance
LP+V	Localizer Performance with advisory vertical guidance
LPV	Localizer Performance with vertical guidance
L/VNAV	Lateral Navigation and Vertical Navigation approach
LSK	Line select key
MCP	Maximum Continuous Power
MFD	Multifunction display
MGB	Main gearbox
MISC	Miscellaneous
MSG	Message
MSTR	Master
MTOW	Maximum Takeoff weight
N1	Gas generator speed
N2	Power turbine speed
NAVD	Navigation display
OAT	Outside air temperature
OBS	Omni Bearing Selector
OEI	One engine inoperative
OGE	Out of ground effect
OVHT	Overheat
PAX	Passenger
pb	Push Button
PWR	Power
QTY	Quantity
RA	Radar altitude
RNAV	Area Navigation
SAS	Stability augmentation system
SBAS	Satellite Based Augmentation System
SEMA	Smart electro-mechanical actuator
SHD (SHED)	Shedding bus
SL, S/L	Search Light
SK	Select Key or Soft Key
STBY	Standby
SUSP	Suspended
SVS	Synthetic Vision System
SYS, SYST	System
TAS	True airspeed
TGB	Tail gearbox
TOP	Takeoff power
TOT	Turbine outlet temperature
TRQ	Torque
TRK	Track
V.APP	Vertical approach
VENT	Ventilation
VFR	Visual Flight Rules
VMS	Vehicle Management System
V <sub>NE</sub>	Never-exceed speed
V <sub>NE power off</sub>	Maximum speed in autorotation
VOR	VHF omnidirectional radio ranging
VRS	Vortex Ring State
VS	Vertical speed
VTOSS	Takeoff safety speed
VY	Best rate-of-climb speed
XFER	Fuel transfer pump
XMSN	Transmission

## MSFS/H160 Default-Function

MSFS-Function	H160 – System	H160 – Function
ROTOR TRIM RESET	Cyclic Control	Trim Release (HOLD)
MAGNETO 3 LEFT	Collective Control	Fill Floats
TOGGLE AUTO HOVER	Cyclic Control	AP/GTC
AUTO HOVER ON	Cyclic Control	AP/GTC (Direct to GTC.H) (Advanced)
AUTOPILOT ON	Cyclic Control	AP/BKUP ON
AUTOPILOT OFF	Cyclic Control	AP/UM OFF
TOGGLE DISENGAGE AUTOPILOT	Cyclic Control	AP/BKUP CUT
AUTOTHROTTLE DISCONNECT	Collective Control	Collective Trim Release (HOLD)
ARM AUTO THROTTLE	Collective Control	OEI HI/LO (Toggle)
AUTO THROTTLE TO GA	Collective Control	GA (Go Around)
ANNUNCIATOR SWITCH OFF	Cyclic Control	Message List RESET
AILERON TRIM RIGHT	Cyclic Control	Cyclic Beep Trim RIGHT
AILERON TRIM LEFT	Cyclic Control	Cyclic Beep Trim LEFT
undefined	Cyclic Control	Cyclic Beep Trim UP
undefined	Cyclic Control	Cyclic Beep Trim DOWN
RUDDER TRIM RIGHT	Collective Control	Collective Beep Trim RIGHT
RUDDER TRIM LEFT	Collective Control	Collective Beep Trim LEFT
RESET RUDDER TRIM	Collective Control	Collective Beep Trim ATT YAW AUTORESET
INCREASE AUTOPILOT N1 REFERENCE	Collective Control	Collective Beep Trim UP
DECREASE AUTOPILOT N1 REFERENCE	Collective Control	Collective Beep Trim DOWN
LANDING LIGHTS UP	Search Light	Steering UP
LANDING LIGHTS DOWN	Search Light	Steering DOWN
LANDING LIGHTS LEFT	Search Light	Steering LEFT
LANDING LIGHTS RIGHT	Search Light	Steering RIGHT
LANDING LIGHTS HOME	Search Light	Steering HOME
TOGGLE WING LIGHTS	Search Light	Light TOGGLE
WING LIGHTS OFF	Search Light	Light OFF
WING LIGHTS ON	Search Light	Light ON
SET CONDITION LEVER	Engine Control Panel (ECP)	Toggle both engines FLIGHT/IDLE
CONDITION LEVER 1 CUT OFF	Engine Control Panel (ECP)	Main 1 OFF
CONDITION LEVER 1 LOW IDLE	Engine Control Panel (ECP)	Main 1 IDLE
CONDITION LEVER 1 HIGH IDLE	Engine Control Panel (ECP)	Main 1 Latch ON
DECREASE CONDITION LEVER 1	Engine Control Panel (ECP)	Main 1 DOWN
INCREASE CONDITION LEVER 1	Engine Control Panel (ECP)	Main 1 UP
CONDITION LEVER 2 CUT OFF	Engine Control Panel (ECP)	Main 2 OFF
CONDITION LEVER 2 LOW IDLE	Engine Control Panel (ECP)	Main 2 IDLE
CONDITION LEVER 2 HIGH IDLE	Engine Control Panel (ECP)	Main 2 Latch ON
DECREASE CONDITION LEVER 2	Engine Control Panel (ECP)	Main 2 DOWN
INCREASE CONDITION LEVER 2	Engine Control Panel (ECP)	Main 2 UP
INCREASE AUTOPILOT REFERENCE VS	Autopilot Control Panel (APCP)	VS Clockwise
DECREASE AUTOPILOT REFERENCE VS	Autopilot Control Panel (APCP)	VS AntiClockwise
INCREASE AUTOPILOT REFERENCE AIRSPEED	Autopilot Control Panel (APCP)	IAS Clockwise
DECREASE AUTOPILOT REFERENCE AIRSPEED	Autopilot Control Panel (APCP)	IAS AntiClockwise
TOGGLE AUTOPILOT RADIO ALTITUDE MODE	Autopilot Control Panel (APCP)	CR.HT TOGGLE
AUTOPILOT RADIO ALTITUDE MODE ON	Autopilot Control Panel (APCP)	CR.HT ON
AUTOPILOT RADIO ALTITUDE MODE OFF	Autopilot Control Panel (APCP)	CR.HT OFF
AUTOPILOT AIRSPEED HOLD	Autopilot Control Panel (APCP)	IAS TOGGLE
AUTOPILOT AIRSPEED HOLD ON	Autopilot Control Panel (APCP)	IAS ON
AUTOPILOT AIRSPEED HOLD OFF	Autopilot Control Panel (APCP)	IAS OFF
TOGGLE AUTOPILOT ALTITUDE HOLD	Autopilot Control Panel (APCP)	ALT TOGGLE
AUTOPILOT ALTITUDE HOLD ON	Autopilot Control Panel (APCP)	ALT ON
AUTOPILOT ALTITUDE HOLD OFF	Autopilot Control Panel (APCP)	ALT OFF
TOGGLE AUTOPILOT HEADING HOLD	Autopilot Control Panel (APCP)	HDG TOGGLE
AUTOPILOT HEADING HOLD ON	Autopilot Control Panel (APCP)	HDG ON

AUTOPILOT HEADING HOLD OFF	Autopilot Control Panel (APCP)	HDG OFF
TOGGLE AUTOPILOT VS HOLD	Autopilot Control Panel (APCP)	VS TOGGLE
AUTOPILOT VS HOLD ON	Autopilot Control Panel (APCP)	VS ON
AUTOPILOT VS HOLD OFF	Autopilot Control Panel (APCP)	VS OFF
SET FUEL TRANSFER AUTO	Overhead Panel	Fuel Transfer Forward ON
SET FUEL TRANSFER OFF	Overhead Panel	Fuel Transfer Forward OFF
SET FUEL TRANSFER FORWARD	Overhead Panel	Fuel Transfer Aft ON
SET FUEL TRANSFER AFT	Overhead Panel	Fuel Transfer Aft OFF
TOGGLE PRIMER 1	Overhead Panel	Fuel Engine 1 Prime ON
TOGGLE PRIMER 2	Overhead Panel	Fuel Engine 1 Prime OFF
TOGGLE PRIMER 3	Overhead Panel	Fuel Engine 2 Prime ON
TOGGLE PRIMER 4	Overhead Panel	Fuel Engine 2 Prime OFF
INCREASE ALTITUDE PRESSURE	Overhead Panel	Master Battery UP
DECREASE ALTITUDE PRESSURE	Overhead Panel	Master Battery DOWN
MAGNETO 3 BOTH	Tablet	Hinge Open/Close
INCREASE MAGNETO 3	Cabin	Cockpit Door Right TOGGLE
DECREASE MAGNETO 3	Cabin	Cockpit Door Left TOGGLE
MAGNETO 3 START	Misc	Master Brightness Increase
SET MAGNETO 3	Misc	Master Brightness Decrease
MAGNETO 2 BOTH	Cyclic Control	Set New Cyclic Center
MAGNETO 2 START	Cyclic Control	Displace Cyclic Center (Force Trim)
MAGNETO 4 START	Autopilot Control Panel (APCP)	A.TRIM TOGGLE
AUTOPILOT NAV1 HOLD	MFDs	MFD2 SoftKey Bottom 1
AUTOPILOT NAV1 HOLD ON	MFDs	MFD2 SoftKey Bottom 1
INCREASE MIXTURE 4	Search Light	Steering UP
DECREASE MIXTURE 4	Search Light	Steering DOWN
INCREASE MIXTURE 3	Search Light	Steering LEFT
DECREASE MIXTURE 3	Search Light	Steering RIGHT
TOGGLE VARIOMETER SWITCH	Engine Control Panel (ECP)	Toggle both engines FLIGHT/IDLE
TOGGLE ENGINE MASTER 1	Engine Control Panel (ECP)	Main 1 UP
TOGGLE ENGINE MASTER 2	Engine Control Panel (ECP)	Main 1 DOWN
TOGGLE ENGINE MASTER 3	Engine Control Panel (ECP)	Main 2 UP
TOGGLE ENGINE MASTER 4	Engine Control Panel (ECP)	Main 2 DOWN
DECREASE EGT 3	Engine Control Panel (ECP)	Main 1 Latch OFF
DECREASE EGT 3	Engine Control Panel (ECP)	Main 1 OFF
INCREASE EGT 3	Engine Control Panel (ECP)	Main 1 Latch OFF
INCREASE EGT 3	Engine Control Panel (ECP)	Main 1 IDLE
SET EGT 3	Engine Control Panel (ECP)	Main 1 Latch ON
SET EGT 3	Engine Control Panel (ECP)	Main 1 FLIGHT
DECREASE EGT 4	Engine Control Panel (ECP)	Main 2 Latch OFF
DECREASE EGT 4	Engine Control Panel (ECP)	Main 2 OFF
INCREASE EGT 4	Engine Control Panel (ECP)	Main 2 Latch OFF
INCREASE EGT 4	Engine Control Panel (ECP)	Main 2 IDLE
SET EGT 4	Engine Control Panel (ECP)	Main 2 Latch ON
SET EGT 4	Engine Control Panel (ECP)	Main 2 FLIGHT
MAGNETO 4 BOTH	Collective Control	GA (Go Around)
TOGGLE ENGINE 3 ANTI ICE	Cyclic Control	AP/GTC
TOGGLE ENGINE 4 ANTI ICE	Cyclic Control	Trim Release (HOLD)
MAGNETO 4 OFF	Cyclic Control	AP/BKUP ON
SET MAGNETO 4	Cyclic Control	AP/BKUP CUT
MAGNETO 4 LEFT	Collective Control	Collective Trim Release (HOLD)
MAGNETO 4 RIGHT	Collective Control	OEI HI/LO (Toggle)
MAGNETO 3 OFF	Cyclic Control	Message List RESET
INCREASE MAGNETO 4	Autopilot Control Panel (APCP)	CR.HT TOGGLE
INCREASE PROPELLER 4 PITCH (SMALL)	Collective Control	Collective Beep Trim UP
DECREASE PROPELLER 4 PITCH (SMALL)	Collective Control	Collective Beep Trim DOWN
MAGNETO 3 RIGHT	Cyclic Control	AP/UM OFF
INCREASE PROPELLER 3 PITCH	Cyclic Control	Cyclic Beep Trim RIGHT
DECREASE PROPELLER 3 PITCH	Cyclic Control	Cyclic Beep Trim LEFT

INCREASE PROPELLER 4 PITCH	Cyclic Control	Cyclic Beep Trim UP
DECREASE PROPELLER 4 PITCH	Cyclic Control	Cyclic Beep Trim DOWN
INCREASE PROPELLER 3 PITCH (SMALL)	Collective Control	Collective Beep Trim RIGHT
DECREASE PROPELLER 3 PITCH (SMALL)	Collective Control	Collective Beep Trim LEFT

## Changelog H160

Here is the Changelog of the H160

### .83

- Increased cyclic stability like H145.496.1
- Increased yaw stability like H145.495
- GTC.H trim release now updates the position datum
- Adjust IAS mode for high speed
- maybe small adjustments to override like H145 (but they didn't really work the same)
- Slow vtrim again to make hover easier
- GTC lateral is available up to ~30kt before switching to coordinated flight
- Pilot visibility sped up 4x
- collective to cyclicY coupling
- fix blue/green cross alignment
- override setting to 0
- rotor debug works again
- HTAWS v2, offline, more range, progressive load (performance), non-aircraft location support
- GS/GP capture fix
- 20ms priority for vtrim task
- Plus changes from build 78 and earlier

### .82

- GTC.H trim release now updates the position datum
- Adjust IAS mode for high speed
- maybe small adjustments to override like H145 (but they didn't really work the same)
- Slow vtrim again to make hover easier
- GTC lateral is available up to ~30kt before switching to coordinated flight
- Pilot visibility sped up 4x
- collective to cyclicY coupling
- fix blue/green cross alignment
- override setting to 0
- rotor debug works again
- HTAWS v2, offline, more range, progressive load (performance), non-aircraft location support
- GS/GP capture fix
- 20ms priority for vtrim task
- Plus changes from build 78 and earlier

#### KNOWN ISSUES

NOTE: import from world map to MFS is partially here but not working properly. don't select a FPL from world map if you are using the CMA9000 FMS.

#### HTAWS DATA

you must install hpg-htaws-data into Community for HTAWS to work  
HTAWS no longer uses the network, so you need to install the terrain database into your Community folder (just once).

### .78

- Quicker response after interacting with some MFD functions
- OVERRIDE status text  
Increase update speed of SYSTEM\_COLLECTIVE\_USER
- Fix degree symbol rendering in tablet mission app message area
- CARLS and NPX138 radios will respond more quickly to power on/off
- get\_locals function to list all locals and their value

### .77

- Fix FND.SCT not working
- Fix VMS NUM not working
- Mission objects waypoint tracking schedule to 20ms/high only while a mission is active
- Mission object management continues while sim is paused
- More precision timing for tasks
- Fix for A character next to degree symbol / bad encoding
- Speed up slip/skid indicator on FND

## Changelog User Guide

The changelog is constantly updated with the H160 version history on [.https://davux.com/docs/h160/](https://davux.com/docs/h160/)

Preview Release: 1.1 (Build 83)

Stable Release: 1.1 (Build 48)

<b>V1.10</b>	<b>April 2026</b>	
V1.9.1	March 2026	Add OSM-tip
<b>V1.9</b>	<b>February 2026</b>	
V1.8.2	February 2026	Add "Installation with the download file"
V1.8.1	January 2026	Add "night vision" to "Tips & Tricks"
<b>V1.8</b>	<b>December 2025</b>	
V1.7.3	December 2025	Add article to "Troubleshooting"
V1.7.2	November 2025	Add article to "Tips & Tricks"
V1.7.1	October 2025	Add recommend for non spring cyclic in tablet setup (V2) ("ignore" at "Hands on")
<b>V1.7</b>	<b>July 2025</b>	
V1.6.4	June 2025	Add Historical
V1.6.3	June 2025	Add Specifications
V1.6.2	June 2025	Add "common mistakes with MSFSLayoutGenerator" to the installation chapter and "how to find community folder"
V1.6.1	May 2025	Some spelling mistakes corrected; Add info for landing light
<b>V1.6</b>	<b>May 2025</b>	
V1.5.2	May 2025	Add SU2 workaround to Installation; add "copy&install" to Installation; add "TDS GTNXi" to "known issues"; add "how to make an approach" to "Tips and Tricks"
V1.5.1	April 2025	Add "Trim release" to Tips and Tricks
<b>V1.5</b>	<b>Mar. 2025</b>	
V1.4.3	Mar. 2025	Add Installation and Known Issues for MSFS 2024
V1.4.2	Mar. 2025	Add MSFS 2024 Settings
V1.4.1	Jan. 2025	correct older configuration
<b>V1.4</b>	<b>Nov. 2024</b>	
V1.3.6	Nov. 2024	MSG info on MFD FND
V1.3.5	Okt. 2024	SVS warning on MFD FND
V1.3.4	Okt. 2024	09.10.24 add "Correct setting of Trim Release" to Tipps&Tricks
V1.3.3	Okt. 2024	add "How are helicopter buttons configured?"-Chapter
V1.3.2	Sept. 2024	add "How to find the community folder" in troubleshooting
V1.3.1	Sept.2024	add changelog for the last H160 versions
<b>V1.3</b>	<b>Sept.2024</b>	
V1.2.1	Aug. 2024	changed transponder call on DMAP page from PMS-50 to GTN-750 and add same sentence on NAVD
<b>V 1.2</b>	<b>Aug. 2024</b>	
V 1.1.2	Aug. 2024	added User Guide version and download link at first page
V 1.1.1	Aug. 2024	removed WTT entry, add HTAWS installation
<b>V 1.1</b>	<b>July 2024</b>	
V 1.0.3	July 2024	Changes for Build .82
V 1.0.2	July 2024	Start Tipps&Tricks, change "REWARD.." to "HELIPAD.." takeoff proc., added "wait.." sentence there, correct NR-Hi off to check
V 1.0.1	June 2024	Headline, better reading for some tables, Link to EFB Connect
<b>V 1.0</b>	<b>June 2024</b>	

April 2024 – Start work